

RTD-10 Control Interface v1.04

Installation and Operating Instructions

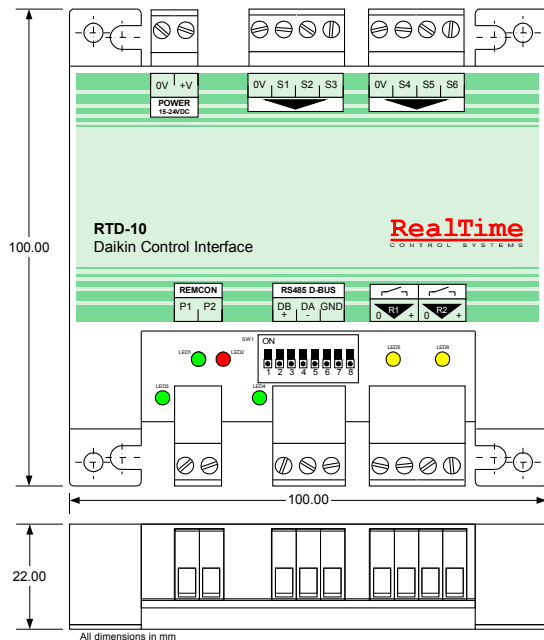

All dimensions in mm

RTD-10 Description

The RTD-10 is a monitoring and control interface for Daikin VRV and Skyair ranges of air-conditioners; and VAM and VKM ventilation units. The interface is compatible with all units that have a P1,P2 remote controller network connection and allows control of up to 16 units in a single group.

Control Functions

HARDWIRED CONTROL. Unit control can be achieved through resistance inputs using resistor, potentiometer and volt-free contact inputs.

BMS INTEGRATION. Unit control can be achieved through 1-10V voltage inputs integrated with BMS control outputs.

HEATING INTERLOCK. Units can be interlocked with external heating systems.

DUTY/STANDBY. Multiple groups can be operated with rotating duty/standby with fault and high temperature alarming.

MODBUS CONTROL. The RTD supports the Modbus Protocol for network control and monitoring.

CUSTOM CONTROL. RTD interfaces can be supplied in custom configurations to suit specific applications.

Warnings and Cautions



Do not exceed the specified fault relay ratings

Observe precautions for handling Electrostatic Sensitive Devices

Mounting

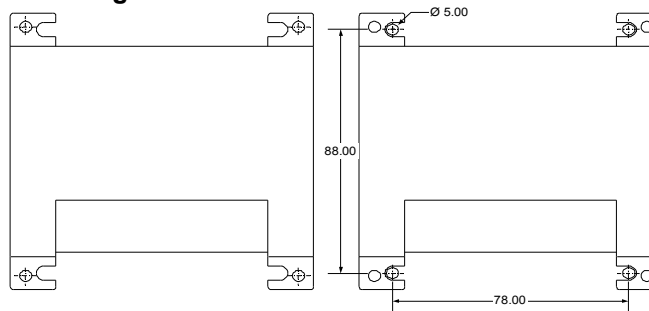

MOUNTING PILLARS

The RTD-10 is supplied with 4 mounting pillars that can be used to mount the interface within units with compatible mounting holes

SCREW MOUNTING

The RTD-10 can be mounted using screws of up to 5mm diameter.

The RTD-10 can be mounted horizontally or vertically.

Power Supply

The RTD-10 requires a 15V to 24VDC power connection. Power can be supplied from VRV indoor unit PCB X18A connection, a Skyair indoor unit PCB X35A connection or VAM PCB X11A connection. A 1m cable and connector is supplied with the RTD-10.

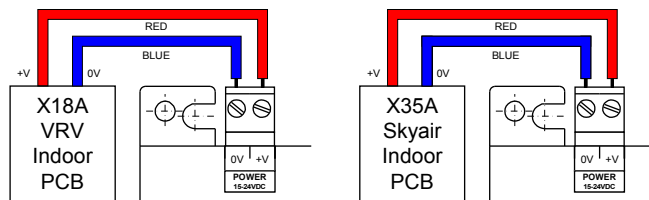

P1,P2 Network

Terminals P1, P2 connect to the Daikin P1, P2 network. P1,P2 installation should follow Daikin installation specifications. The RTD-10 can operate in Master or Slave mode with any Daikin remote controller. Operation is also possible without a remote controller being connected. Note that infra-red receivers must be configured to operate in slave mode.

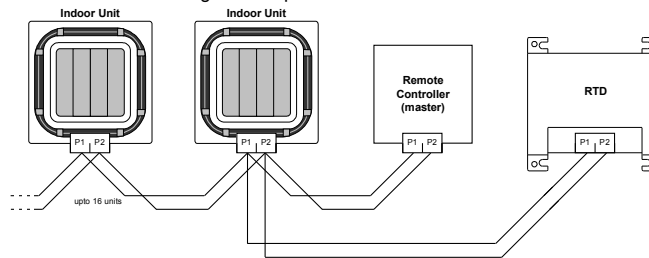

Standard Control

The RTD-10 can be configured to operate in several different modes using the configuration DIP switches SW1.1 to SW1.4. In Standard Control the following combinations of modes are available:

Input Mode	Resistance	Voltage
Relay R1 Output	Unit Run	Defrost Operation
Setpoint Limit	No Limit	Limit 19 to 23

Standard Control: Resistance

In Resistance Control Mode the RTD-10 Inputs allow individual control of a/c unit operating parameters using resistance values. Each input corresponds to a specific unit setting shown in the table below. If an input is left unconnected then the corresponding setting will remain at the default value.

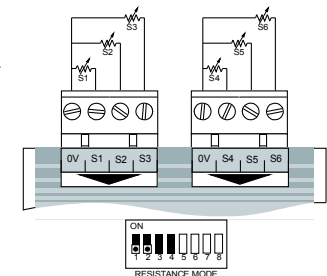

S1	Setpoint	0..10kΩ : 16..32°C (22)
S2	Fanspeed	Low<=1.1kΩ, High=2.2kΩ, HighHigh*=3.3kΩ
S3	Mode	Auto<=1.1kΩ, Heat=2.2kΩ, Fan=3.3kΩ, Cool=4.7kΩ, Dry=6.8kΩ,
S4	Louvre	Swing<=1.1kΩ, 0°=2.2kΩ, 20°=3.3kΩ, 70°=4.7kΩ, 90°=6.8kΩ,
S5	On/off	On = Closed Circuit, Off = Open Circuit
S6	Unlock	Lock All<=1.1kΩ, Lock Setpoint, Mode, On/Off= 2.2kΩ, Lock Mode, On/Off=3.3kΩ, Lock On/Off=4.7kΩ, Local=6.8kΩ, Lock Mode=9.6kΩ, Unlock>15kΩ

*HighHigh fanspeed operates if available, otherwise selects High fanspeed

S1 kΩ	0.3	0.9	1.5	2.1	2.6	3.2	3.8	4.4	5.0	5.6	6.2	6.8	7.4	7.9	8.5	9.1	9.7
--------------	-----	-----	-----	-----	-----	-----	-----	-----	-----	-----	-----	-----	-----	-----	-----	-----	-----

R1	Run/Defrost	Run: SW1.3 OFF : Closed when unit switched ON Defrost: SW1.3 ON : Closed when unit in defrost
R2	Fault	Closed on any unit fault

Caution: Relays rated for maximum 1A, 24VAC/30VDC

Resistances should be within +/-250 ohms of the quoted value. Open circuit is R>200kΩ. S1 in resistance mode is designed to be operated using a linear 10kΩ variable resistance.

It is recommended that volt-free contacts or switch mechanisms have gold plated contacts to ensure a low resistance circuit when the switch is made.

S1 to S6 cables should be 0.5 to 1.0 mm² multi-stranded screened twisted pair. The screen should be earthed at one end only. The maximum distance from the RTD-10 to the input source is 200m.

Standard Control: Voltage

In Voltage Control Mode the RTD-10 Inputs allow individual control of a/c unit operating parameters using voltages. Each input corresponds to a specific unit setting shown in the table below. If an input is left unconnected or is set to 0 Volts then the corresponding setting will remain at the default value.

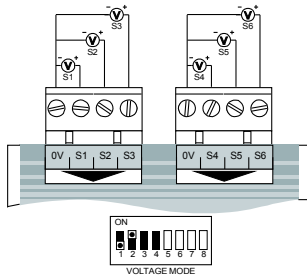

Input	Name	Range (default / 0V value)
S1	Setpoint	1..10V : 16..32°C (22)
S2	Fanspeed	Low=1.75V, High=3.25V, HighHigh*=4.75V
S3	Mode	Auto=1.75V, Heat=3.25V, Fan=4.75V, Cool=6.25V, Dry=7.75V,
S4	Louvre	Swing=1.75V, 0°=3.25V, 20°=4.75V, 70°=6.25V, 90°=7.75V,
S5	On/off	On >=5V, Off = 0V
S6	Unlock	Lock All=1.75V, Lock Setpoint, Mode, On/Off=3.25V, Lock Mode, On/Off=4.75V, Lock On/Off=6.25V, Local=7.75V, Lock Mode=9.25V, Unlock=10.0V

*HighHigh fanspeed operates if available, otherwise selects High fanspeed

Output	Name	Operation
R1	Run/ Defrost	Run: SW1.3 OFF : Closed when unit switched ON Defrost: SW1.3 ON : Closed when unit in defrost
R2	Fault	Closed on any unit fault

Caution: Relays rated for maximum 1A, 24VAC/30VDC

Voltages should be within +/- 0.25V of the quoted value. Open circuit for V<1V.

Standard Control: Relay R1 Output

SW1.3 configures Relay R1 as either a Run signal that closes when the unit is enabled to run, or a Defrost signal that indicates when the unit is in Defrost.

Standard Control: Setpoint Limit

If SW1.4 is ON then a setpoint limit of 19 to 23 degrees is applied to setpoint adjustments made from the Remote Controller or Central Controller. Setpoint Limiting only applies when the setpoint buttons are unlocked and the keypad Unlock input S6 is NOT set to Local. The setpoint limits are not applies to setpoint control from input S1 or adjustment via Modbus commands.

Standard Control: Remote Controller Unlock

Input S6 in Voltage or Resistance mode can configure the unlock state of the Remote Controller buttons. The default state is **Unlock**, in this state the Remote Controller buttons are all active and no lock symbol appears on the display. Updates from inputs S1 to S5 are only sent when the input changes so that users can still operate the A/C. Setting S6 to **Locked** locks all input buttons and updates from the inputs S1 to S5 will control the operation of the A/C. Several partial Lock states allow combinations of the Setpoint, Mode and On/Off buttons to be locked so that the user has partial control of the unit. Setting S6 to **Local** unlocks all remote controller buttons and prevents any control updates from inputs S1 to S5.

Heating System Interlock

The RTD-10 can be configured to operate in Heating System Interlock mode to prevent A/C cooling or heating operation from conflicting with the operation of an additional system. The RTD-10 can be wired to operate either in Master mode in which the RTD-10 determines when the secondary system operates, or Slave mode in which the secondary system will inhibit the RTD-10 operation.

Inputs are the same as Resistance Control Mode, with input S4 changed to act as an operation inhibit input signal. Closed circuit inputs on S1 to S3 select additional functions and override the default behaviour of the input.

Input	Name	Range (default)
S1	Setpoint	0.3..10kΩ : 16..32°C (22) Restart Inhibit = Closed Circuit (Setpoint Control not available)
S2	Fanspeed	Low=1.1kΩ, High=2.2kΩ, HighHigh*=3.3kΩ Invert S4 Input = Closed Circuit (Fanspeed Control not available)
S3	Mode	Auto=1.1kΩ, Heat=2.2kΩ, Fan=3.3kΩ, Cool=4.7kΩ, Dry=6.8kΩ, Heat/Cool Mode Inhibit = Closed Circuit (Mode Control not available)
S4	Inhibit	Inhibit=Closed Circuit, Enable = Open Circuit
S5	On/off	On = Closed Circuit, Off = Open Circuit
S6	Unlock	Lock All<=1.1kΩ, Lock Setpoint, Mode, On/Off= 2.2kΩ, Lock Mode, On/Off=3.3kΩ, Lock On/Off=4.7kΩ, Local=6.8kΩ, Lock Mode=9.6kΩ, Unlock>15kΩ

*HighHigh fanspeed operates if available, otherwise selects High fanspeed

Output	Name	Operation
R1	Mode Interlock	SW1.3 OFF: Closed if Mode Auto:Cool, Cool or Dry + Unit On SW1.3 ON: Closed if Mode Auto:Heat or Heat + Unit On
R2	Fault	Closed on any unit fault

Caution: Relays rated for maximum 1A, 24VAC/30VDC

INTERLOCK MASTER MODE

To operate the RTD-10 in Interlock Master Mode the relay output R1 is wired as an input to the secondary system. With SW1.3 OFF R1 will close when the unit is On and in a cooling mode. With SW1.3 ON R1 will close when the unit is On and in a heating mode. If the unit is in fault then R1 will not operate.

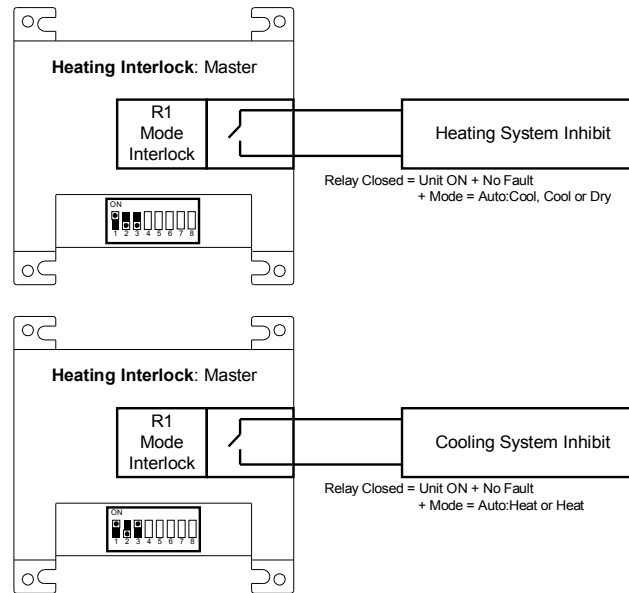

INTERLOCK SLAVE MODE

To operate in slave mode the input S4 operates as a Volt-free inhibit input. When the inhibit signal is closed circuit the RTD-10 will prevent the A/C unit from operating. Input S4 operation can be inverted by inserting a Short Circuit on input S2.

The RTD-10 can be configured using switch SW1.4 to switch the A/C units OFF during the inhibit or to switch the units to FAN-ONLY or Mode Inhibit. The inhibit signal overrides on/off commands both from the Remote Controller as well as input S5. If A/C Fan-Only mode is selected then the unit will remain on and the unit mode will be switched to Fan-only and locked. If Mode Prohibit is selected then the Mode will be prevented from operating in Auto and Heat if Heating Inhibit is selected (SW1.3 OFF), and will be prevented from operating in Auto, Cool and Dry if Cooling Prohibit is selected (SW1.3 ON).

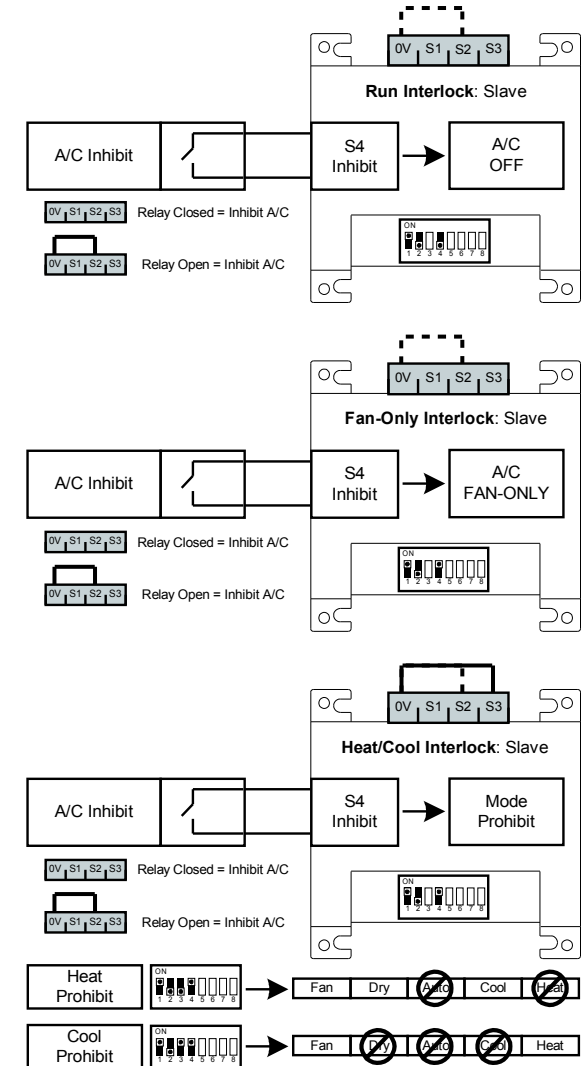

When the inhibit signal is removed the RTD-10 will restore the previous operating state of units. If input S1 is Short Circuited then the previous settings will not be restored when the interlock is removed.

Duty/Standby Operation

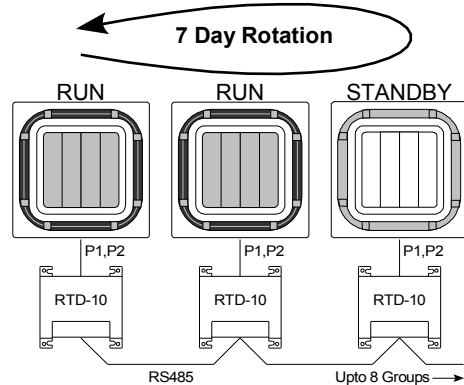

The RTD-10 can be configured to operate in a duty/standby configuration suitable for IT and Telecoms applications. An RTD-10 master together with up to 7 RTD-10 slaves can be configured to operate in a rotating duty/standby configuration with the following features:

- Up to 8 duty/standby groups
- All units run on fault
- 1 or 2 standby units
- Daily, Weekly or Multi-week duty rotation
- Two level alarm on high temperature and unit fault
- Thermistor space temperature alarm
- A7 (Louvre) fault code filtering

DUTY/STANDBY OPERATION

Under 'no fault' conditions the system will operate with 1 or 2 units in standby and the remaining units operational (2 unit standby is only available if there are at least three RTD groups). Default rotation time is 7 days, input S3 can be configured to select rotation times of 1 day, 2 weeks or 4 weeks if required using specific resistor values. In addition a test-mode is available by placing a 0 ohm link on S3 which will cause the system to operate in test mode with a 60 second rotation time. The system should only be operated in test mode for short time periods.

The RTD-10 with Address 0 (SW1.5 to SW1.8 OFF) is the Duty/Standby master. All inputs and outputs are wired to the Master. Slave inputs should not be wired. Slave output relays indicate the Alarm Level for that slave only.

A/C UNIT OPERATION

The unit mode is set to COOL and the mode button on the Master remote controller is locked to prevent change. The on/off button is also locked. The setpoint and fanspeed can be set from the RTD-10 master or the remote controller on the master group. If S1 and S2 are wired then setpoint and fanspeed are set by the RTD-10 inputs and the corresponding buttons on the remote controller are locked. If S1 and S2 are not wired then the buttons on the master remote controller are unlocked and can be used to set operating values. In this mode the setpoint is **limited** to the range 20 to 32°C.

Duty/Standby Operation

ALARM OPERATION

Relay outputs R1 and R2 on the Master RTD-10 operate respectively as Level 1 and Level 2 alarm outputs. If a Level 2 alarm occurs then both R1 *and* R2 will be closed. All units will run if a Level 1 or Level 2 alarm occurs.

All unit return air temperatures are monitored and alarm levels 1 and 2 are set respectively at 2°C and 4°C above operating setpoint. The Auxiliary Space Temperature sensor has the same alarm limits applied.

Any unit fault other than code A7 will result in a Level 2 alarm being generated. An A7 (louvre fault) will generate a Level 1 alarm, but will not force units on.

The RTD-10 master will monitor all of the RTD slave devices discovered after power-up. If any of the RTD slave devices fail to respond the RTD-10 will raise a Level 2 alarm after 1 to 2 minutes.

Alarm	Reasons
Alarm Level 1 Output R1	Unit Return Air > Setpoint + 2°C Aux. Space Temperature > Setpoint + 2°C A/C Unit Louvre Fault (A7) Alarm Level 2 Exists
Alarm Level 2 Output R2	Unit Return Air > Setpoint + 4°C Aux. Space Temperature > Setpoint + 4°C A/C Unit Fault (except A7) A/C Unit Missing (U5 Fault) RTD-10 Slave Missing (master RTD-10) RTD-10 No slaves found (master RTD-10) RTD-10 Master not found (slave RTD-10)

If a Level 1 or Level 2 alarm occurs due to a unit or communications fault then all units will run until all faults are cleared.

If a Level 1 or Level 2 alarm occurs due to a high temperature on an indoor unit or the Auxiliary Space sensor then all units will run until temperature has reset and will continue to run on for 20 minutes before reverting to normal Run/Standby operation. In Test Mode (rotation = 60s) the run on time will be 40 seconds..

If a Level 2 alarm occurs due to an Indoor Unit Fault then all units will run until the Indoor Unit Fault has cleared and will continue to run on for 10 minutes before reverting to normal Run/Standby operation. In Test Mode (rotation = 60s) the run on time will be 20 seconds.

OVERRIDE ALL ON/OFF

Input S5 is a volt-free contact input that overrides all units ON if closed circuit. Input S6 is a volt-free contact input which overrides all units OFF if closed circuit.

AUXILLIARY SPACE SENSOR

An auxiliary space sensor is required to provide alarm monitoring in the controlled space.

The sensor should be a 10kΩ NTC Thermistor mounted on a suitable vertical surface in the monitored space. The sensor should be wired to the RTD-10 using a twisted pair cable no longer than 100 metres. The Auxiliary sensor will raise alarms even if the units are overridden off.

Duty/Standby Operation

INSTALLATION

All RTD interfaces must be networked together using the 3 wire RS485 network, each RTD must then have a network address set in the range 0 to 7 (see section *RTD Networking*). The RTD-10 Duty/Standby Master must have an address of 0. The remaining RTD slaves should have addresses in the range 1 to 7. If there are less than 7 slaves then start the addressing at 1 and allocate each slave consecutively upwards.

The Master and Slave RTD-10s will both initially indicate a Level 2 alarm. The master alarm will clear when it discovers at least one slave RTD-10. The slave alarm will clear when the master discovers the slave. If communications fails with a slave RTD-10 the master will generate a Level 2 alarm after 120s.

CONFIGURATION

The Run/Standby configuration is selected using the RTD-10 DIP switch settings. Both master and slave devices must have the DIP switches set. The position of SW1.4 on the master determines whether the system operates with 1 unit or 2 unit standby. The possible switch configurations are as follows:

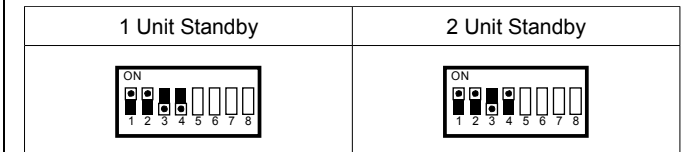

INPUT CONFIGURATION

Input	Name	Range (default)
S1	Setpoint	0..10kΩ : 16..32°C (from RC)
S2	Fanspeed	Low=1.1kΩ, High=2.2kΩ, HighHigh*=3.3kΩ (from RC)
S3	Rotation	60s<=1.1kΩ, 1 Day=2.2kΩ, 1 Week =3.3kΩ, 2 Weeks=4.7kΩ, 4 Weeks=6.8kΩ
S4	Auxiliary Space Temp	10kΩ NTC Thermistor <i>Recommended part: RS Stock No. 813-806</i>
S5	All On	All On = Closed Circuit, Normal Operation = Open Circuit
S6	All Off	All Off = Closed Circuit, Normal Operation = Open Circuit

*HighHigh fanspeed operates if available, otherwise selects High fanspeed

RELAY CONFIGURATION

Output	Name	Operation
R1	Alarm Level 1	Closed when Alarm Level 1 or 2 occurs
R2	Alarm Level 2	Closed when Alarm Level 2 occurs

Caution: Relays rated for maximum 1A, 24VAC/30VDC

MODBUS OPERATION

When operating in Duty/Standby mode the RTD devices CANNOT be connected to an external Modbus Master as this will disrupt operation.

RTD Networking

ADDRESSING

The RTD-10 has the facility to create control groups using multiple RTDs connected together on the RS485 D-Bus network. In standard configuration up to 16 RTD-10 devices can be connected together. Each RTD is assigned a D-Bus address using the configuration switches SW1.5 to SW1.8. Unit addresses are shown below.

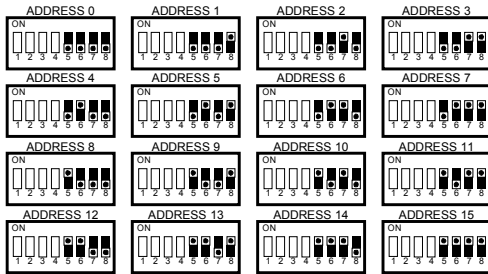

Address 0 is the RTD-10 MASTER address. Address 1 to 15 are RTD-10 SLAVE addresses.

NETWORK INSTALLATION

The RS485 D-Bus network requires a twisted pair cable connecting terminals DB(+) and DA(-) on each RTD as shown below. Terminal DB must be connected to all other DB terminals. Terminal DA must be connected to all other DA terminals. In addition the common terminal GND on all devices must be connected together. If a shielded cable is used then the shield can be used for this purpose. It is recommended that the GND connection is connected to local Earth at one point only. The network must be installed as a daisy-chained point-to-point Bus configuration, Star and Ring connections must NOT be used.

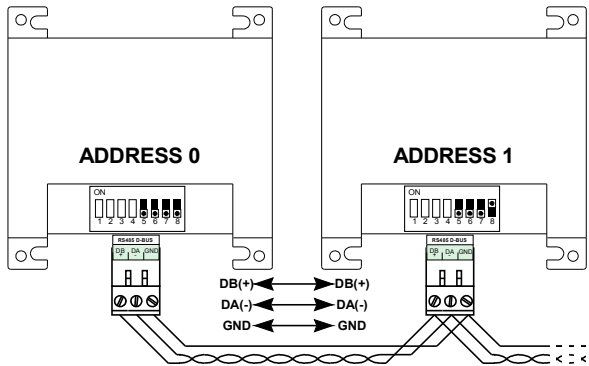

SPECIFICATION

Use stranded 24awg shielded or unshielded twisted pair to Cat3, Cat4 or Cat5 specification. Use a twisted pair for connections DB,DA and an extra core for connection GND.

NETWORK LENGTH

Standard installation for total network distances of up to 500m can be achieved following the basic daisy-chaining method showed in the above diagram. The network can be extended further using RS485 repeaters.

Modbus Operation

CONTROL

The RTD-10 can be operated from both the hard-wired inputs and Modbus register commands if input S6 is open-circuit. Under this mode of operation control updates will be sent if a change is made to either a Modbus register or a wired input. All control registers are analogue **Holding Registers**

MODBUS CONFIGURATION

Network 3 wire RS485
 Mode Modbus RTU Slave
 Baud 9600
 Parity None
 Stop bits 1

Note: RTD interfaces can be configured with different baud rate and parity settings if required

Holding Register	Name	Range
0001	Setpoint	16..32
0002	Fanspeed	1..3 (1:Low, 2:High1, 3: High2*)
0003	Mode	0..4 (0:Auto, 1:Heat, 2:Fan, 3:Cool, 4:Dry)
0004	Louvre	1..7 (1:Swing, 2: 0 Degrees, 3: 20 Degrees, 4:45 Degrees, 5:70 Degrees, 6:90 Degrees)
0005	OnOff	0..1 (0:Off, 1:On)

*Where HighHigh fanspeed is enabled, High1 = High, High2= HighHigh. Otherwise both modes select High

Holding Register	Name	Lock Mode*
0010	All Lock	0:LastTouch, 1:Central, 2:Local, 3:OnChange
0011	Setpoint Lock	0:LastTouch, 1:Central, 2:Local, 3:OnChange
0012	Fanspeed Lock	0:LastTouch, 1:Central, 2:Local, 3:OnChange
0013	Mode Lock	0:LastTouch, 1:Central, 2:Local, 3:OnChange
0014	Louvre Lock	0:LastTouch, 1:Central, 2:Local, 3:OnChange
0015	OnOff Lock	0:LastTouch, 1:Central, 2:Local, 3:OnChange

*Last Touch updates are written to the A/C on every register write. On Change updates are only sent if the value written changes. Central locks the corresponding RC button. Local unlocks the RC button and prevents any updates from the RTD.

MONITORING

Unit data is available for each of the indoor units on the P1,P2 network. All readback data is available in analogue **Input Registers**. Input registers are numbered using the indoor unit number x 100 added to an offset relating to a specific feature. Group data is available as unit 0.

Group*	Unit 1	Unit 2	...	Unit16	Name	Range
0020	0120	0220	...	1620	Unit Exists	0..1
0021	0121	0221	...	1621	Is Fault	0..1
0022	0122	0222	...	1622	Fault Code	0..65535
0023	0123	0223	...	1623	Return Air Temp	Degrees C x 100

* Group **Unit Exists** returns the number of units found. Group **Fault Code** returns the fault code of the first unit in fault. Group **Return Air Temp** returns the average unit temperature.

FAULT CODES

Fault codes are encoded using a standard table to allow standard Daikin fault codes to be generated from the readback value. The **no fault** value is 255.

KEYPAD LOCK

When the keypad is locked using input S6 then Modbus commands will not change the lock state but unit settings can still be adjusted. When the S6 input is set to unlock the keypad then Modbus commands can change the lock state.

Additional Modbus registers and more detailed Modbus engineering instructions are available in the RTD-NET datasheet. available from <http://www.realtime-controls.co.uk/rtd>. A full list of fault codes is also available from this link.

VAM and VKM Unit Operation

VAM and VKM units can be switched on and off using the RTD-10 On/off input. Control of VAM and VKM unit fanspeed and damper position from RTD-10 inputs or from Modbus registers is also possible using extended RTD-10 operating modes.

More details are available from <http://www.realtime-controls.co.uk/rtd>

LED Functionality



Normal Operation

R:	G:	Power-Up sequence Factory Configuration	R:	G:	No Fault State
R:	G:	Power-Up sequence Custom Configuration	R:	G:	Unit Fault
R:	G:	P1,P2 Search. After power-up and during unit configuration			

Error Conditions

R:	G:	Device configuration error
R:	G:	AC Unit Missing (U5 Fault)
R:	G:	RS485 Communications timeout

UNIT SEARCH

When the RTD-10 is powered up, or if it loses communication with the Remote Controller the RTD-10 enters P1,P2 search mode. If P1,P2 communications are not re-established after 1 minute the RTD-10 will raise an alarm which will be indicated on the fault relay output.

Functional Specification

Electrical	Environmental
Supply	Temperature
15V-24V DC, 120mA Regulated	
Power	Storage Operation
<2.5VA	-10oC to 50oC 0oC to 50oC
Relay	Humidity
1A, 24VAC max 1A, 30VDC max	0-90% RH non-condensing
Mechanical	Protection
Dimensions	IP30
H100 x W100 x D22 mm	EMC Emissions
Mounting	EN61000-6-1
Four screw / pillar mounts	EMC Immunity
Casing	EN61000-6-3
Zinc coated mild steel	Inputs
Weight	Voltage Mode
120g	S1..S6 0..10VDC <1mA Maximum Rating 12VDC
Connectors	Resistance Mode
Rising clamp to 0.75mm ² cable	S1..S6 5V, 1mA