

6.2 KRP4AA51 / KRP4AA52 / KRP4AA53 / KRP4A54

Outline / Features

This adaptor is an interface required to connect the indoor unit with the central monitoring panel. And by installing this adaptor in the indoor unit, it enables you to have various remote controls (ON/OFF, temperature setting, operation status display and malfunction display). One adaptor can control simultaneously the group of units (Max. 16 units) connected to the remote control wiring line (P1, P2).

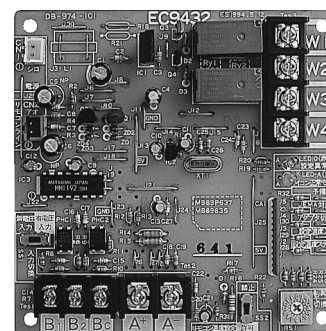

Note:

1. This adaptor cannot be used together with central control equipment and data station.
2. The model of adaptor differs according to the type of indoor unit to be installed.

Applied Model

Applied Model	Remark	Applied Model	Remark	Note
VRV Plus Series	○	SkyAir Series	○	
VRV Inverter "K(A)" "K(U)" Series	○	Room Air-Conditioner	×	
VRV Heat Recovery Series	○	Other Air-Conditioner	×	
VRV II Series	○	HRV Unit	○	BRC1B61, 62 etc. are required.

System Configuration

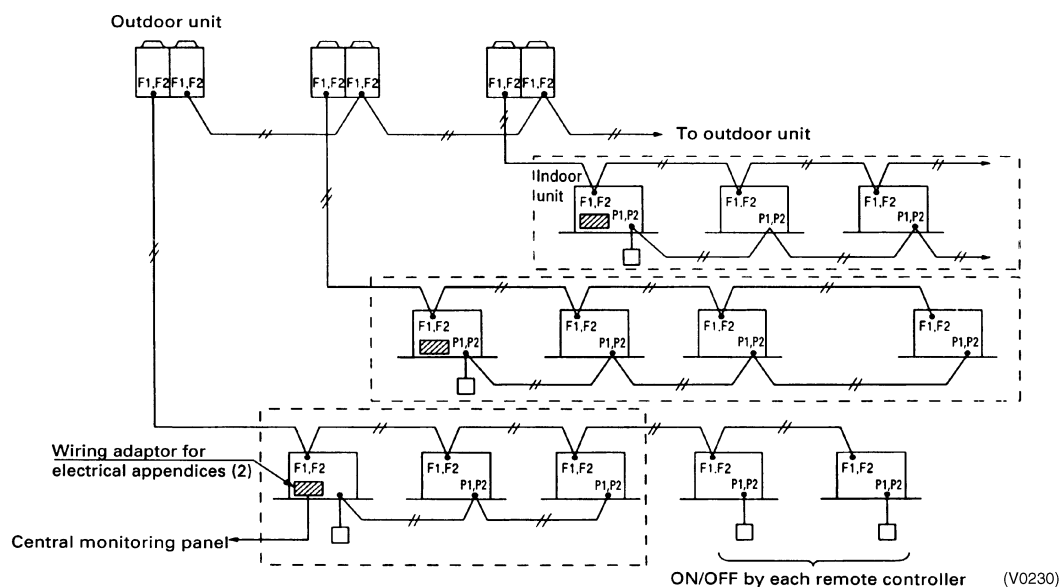

Note:

1. Marked shows wiring adaptor for electrical appendices.
2. Marked indicates the same control range.
3. The wiring adaptor for electrical appendices (2) can control simultaneously the group of the units (Max. 16 units) connected to the remote control wiring line (P1, P2). In another words, all the units connected between P1 and P2 terminal have the same control.

■ Point of wiring

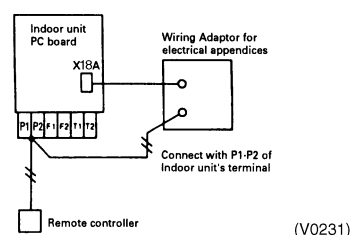

Names and Functions of Operating Part

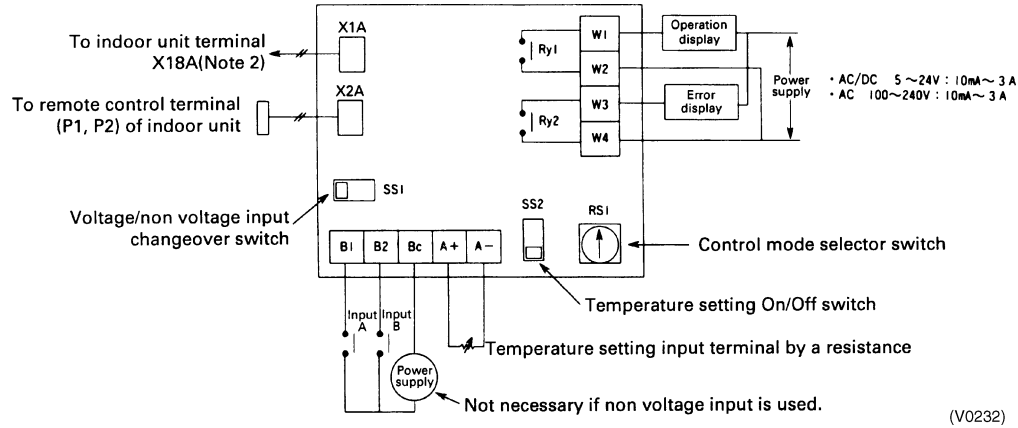

Note:

1. This is valid only for the indoor unit, which has a temperature setting function.
2. Terminal No. X18A is for the indoor unit of VRV system. For SkyAir series and other air-conditioner, connect to the relevant terminal for each units.

Input/Output for External Control

1. Depending on whether [voltage input] or [non voltage input], connect the wiring as shown below.

■ **Input with Voltage.**

Set the Voltage/Non voltage changeover switch (SS1) to VOLT.

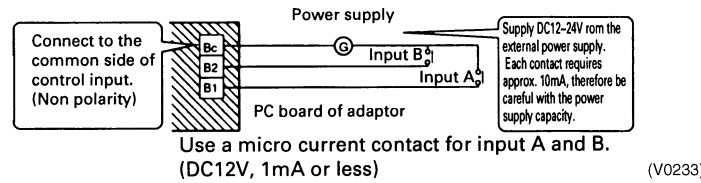

■ **Input with No Voltage.**

Set the Voltage/Non voltage changeover switch (SS1) to NON VOLT.

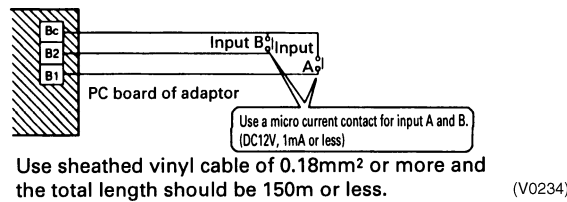

2. Display Signal Retrieval (Output)

The normal operation output terminals (W1, W2) and error output terminals (W3, W4) are non-voltage output contacts. (Permissible current is 10mA~3A per contact.)

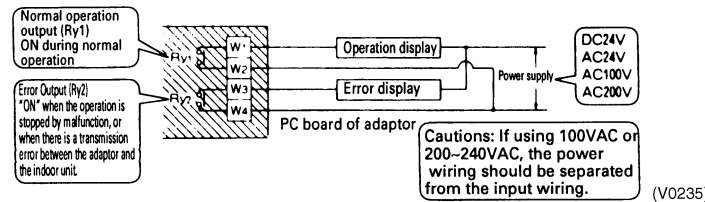

Output is as given below.

Output System	Both Ry1 and Ry2 is OFF.	Only Ry1 is ON.	Only Ry2 is ON.
Group control	OFF	All normal operation	At least one unit is stopped due to error or transmission error between the adaptor and the indoor unit.

3. Temperature Setting Input

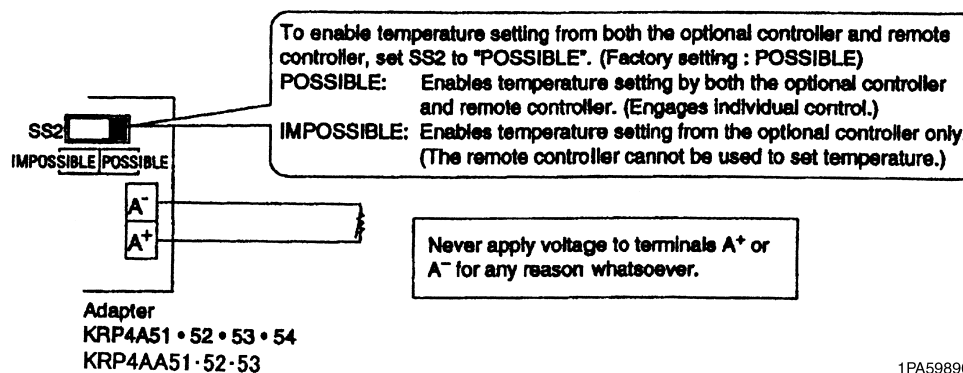

Temperature setting corresponds to resistance values in the range of 0 to 135Ω. Their relationship is as shown below.

Relation between the setting temperature and the resistance are as follows.

Setting temperature (°C)	16	17	18	19	20	21	22	23	24	25	26	27	28	29	30	31	32
Resistance (Ω)	0.0 ~ 3.4	5.0 ~ 11.6	13.8 ~ 20.0	22.4 ~ 28.4	31.0 ~ 36.4	39.4 ~ 44.8	48.2 ~ 52.8	56.6 ~ 61.2	65.2 ~ 69.4	73.8 ~ 77.8	82.4 ~ 85.8	91.0 ~ 94.0	99.4 ~ 102.2	108.6 ~ 110.4	117.2 ~ 119.2	125.8 ~ 127.4	134.2 ~ 140.0

Note:

- The value of resistance includes the resistance of wiring.
- The setting temperature is limited within the setting range of indoor unit. If you set the temperature outside of the range by the adaptor, it controls at the nearest setting range.

Setting of Control Mode Selector Switch (RS1)

Position	Functions	Description of Operation by Input Mode A and B	
		Input A (Between B1~Bc)	Input B (Between B2~Bc)
0	Input Ignored	—	—
1	Remote Control Rejection	Start at ON, and stop at OFF	Stop at ON (remote control rejection), Input A acceptance at OFF
2	Central Priority	Start at ON (remote control acceptance), stop at OFF (remote control rejection)	
3	Remote Control Acceptance/ Rejection	The same as position 1 (Only stop is accepted by remote controller)	
4	Remote Control Acceptance/ Rejection, OFF	Start at ON (remote control acceptance), stop at OFF (remote control rejection)	
5	Remote Control Rejection	Start/Stop (Repeats)	
6	Last Command Priority	The same as position 5 (remote control acceptance all the time)	Stop at ON remote control acceptance), start at OFF (remote control rejection)
7	Remote Control Rejection	Start at ON	Stop at ON.
8	Last Command Priority	Start at ON (remote control acceptance)	Stop at ON (remote control rejection)
9	Remote Control OFF Acceptance	The same as position 7 (Only stop is accepted by remote controller)	The same as position 7
A	Remote Control Acceptance/ Rejection, OFF	Start at ON (remote control acceptance)	Stop at ON (remote control rejection)
B	Last Command Priority	The same as position 7 (remote control acceptance all the time)	The same as position 7
C	Position 5 + Energy Saving Control	The same as position 5	Forced thermostat OFF at ON
D	Position 5 + Temperature Set-Back		Setting temperature shift command at ON
E	Position 6 + Energy Saving Control	The same as position 6	Forced thermostat OFF at ON
F	Position 6 + Temperature Set-Back		Setting temperature shift command at ON

Note:

1. When constant input is used for input B at position 7~A, the system is shut-down forcibly (Ignored input A). Constant input cannot be used for input B at position B.
2. Refer to the followings for the outline of above functions.

■ Description of Functions (Outline)

- 1. Remote Control Rejection..... For when you want to turn ON/OFF only by central remote controller. (ON/OFF cannot be controlled by remote controller for indoor unit.)
- 2. Remote controller OFF Only Accepted For when you want to turn ON only by the central remote controller, and turn OFF only by remote controller for indoor unit.
- 3. Central Priority For when you want to turn ON only by the central remote controller, and during the set time, turn ON/OFF freely by remote controller for indoor unit.
- 4. Individual Priority (Last command priority) For when you want to turn ON/OFF by both central remote controller and remote controller for indoor unit.
- 5. Remote Controller Permission Timer For when you want to turn ON/OFF by remote controller for indoor unit during set time, and you want to start the operation by remote controller for indoor unit at the programmed time of system start.

2

6.2 KRP4AA51 / KRP4AA52 / KRP4AA53 / KRP4AA54

<Example when the control mode selector switch is set at position 6>

The following is the time chart for the command by remote controller and the indoor unit against input signal.

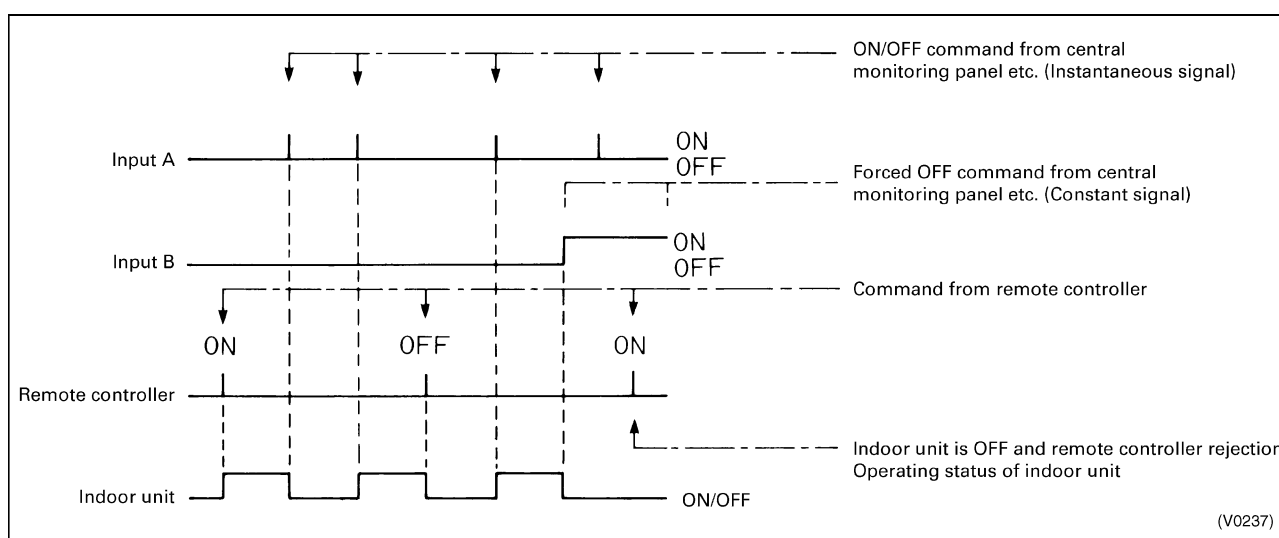

Instruction for Installation

Ceiling Mounted Cassette Type

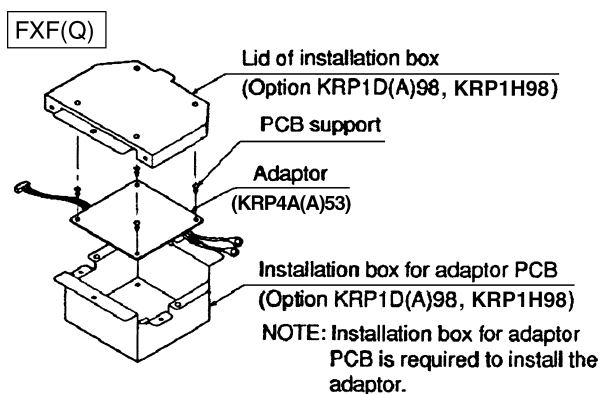

**Slim Ceiling Mounted Duct Type
Ceiling Mounted Cassette Type (Multi-Flow) 600x600**

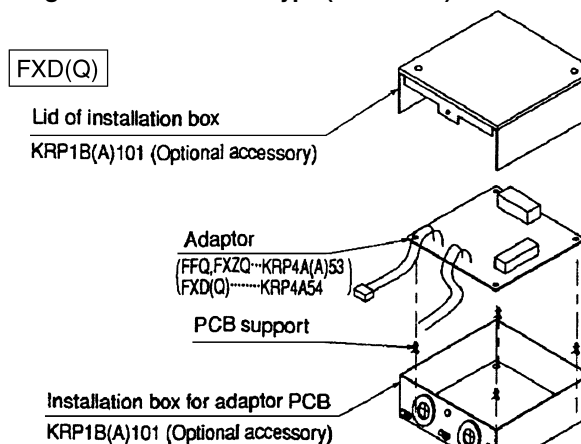

NOTE : Installation box for adaptor PCB is required to install the adaptor.

Ceiling Mounted Cassette Type (Double-Flow)

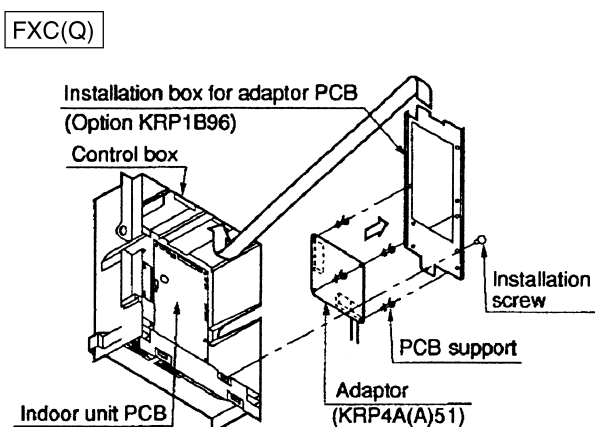

NOTE) A separate plate is needed to install the adaptor PCB.

Ceiling Mounted Cassette Corner Type

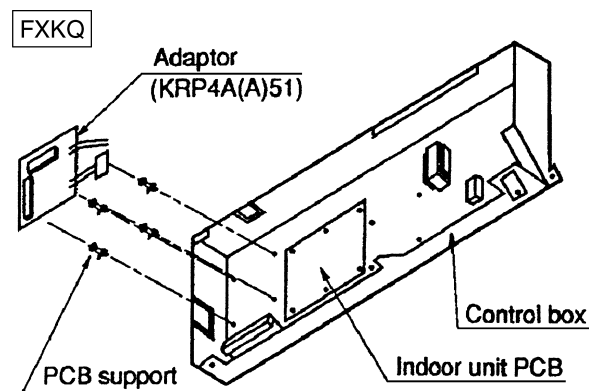

Ceiling Suspended Type

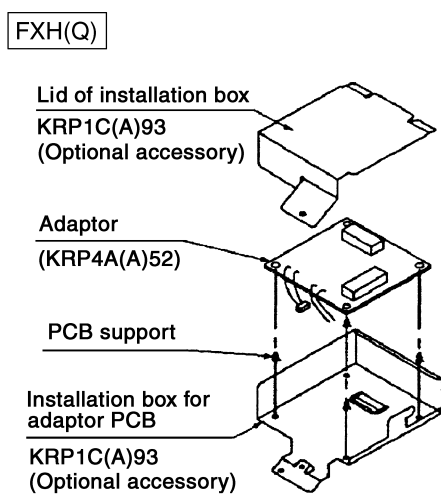

NOTE : Installation box for adaptor PCB is required to install the adaptor.

Note:

The above shows the installation for VRV indoor unit. For the SkyAir series and other air-conditioner, it may be different from the ones showed above and refer to its engineering data for the details.

Ceiling Mounted Built-In Type

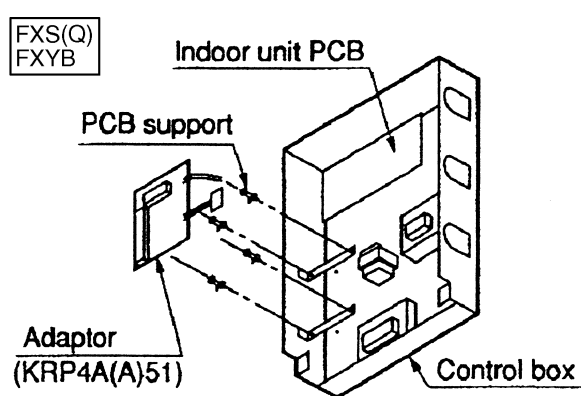

Note :

Installation box is necessary for second adaptor (FXS) .

Ceiling Mounted Duct Type

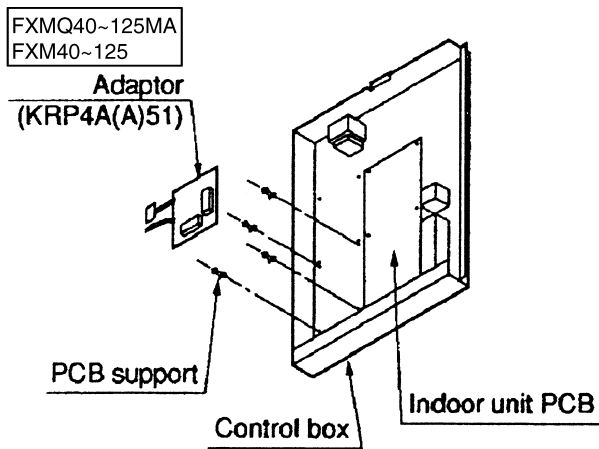

Floor Standing Type

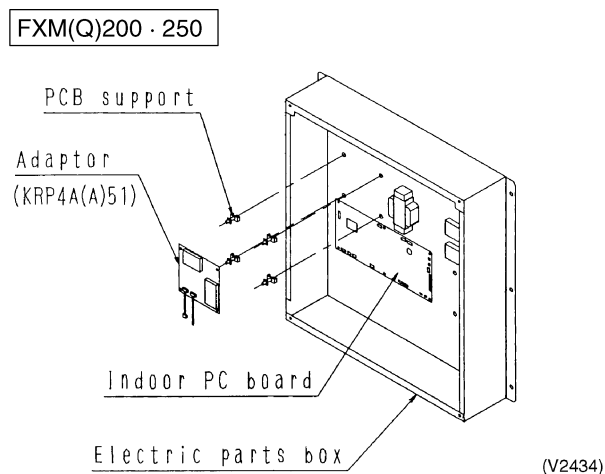
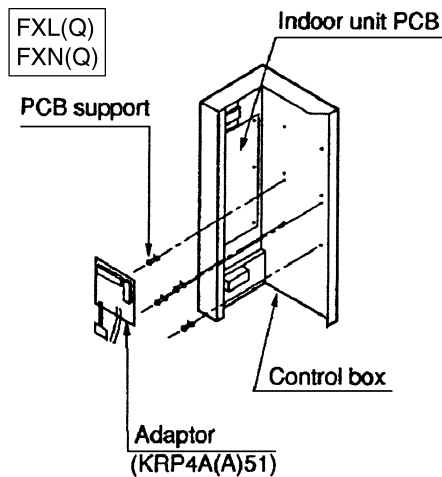

Wall Mounted Type

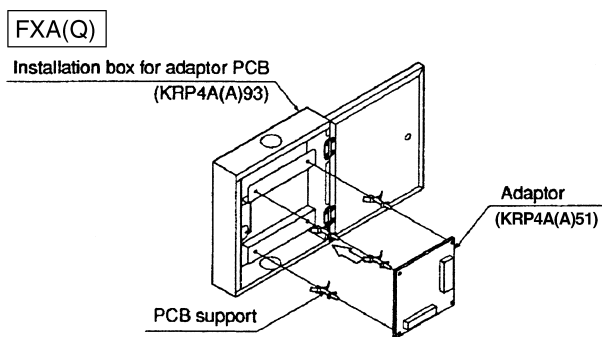

Note:

The above shows the installation for VRV indoor unit. For the SkyAir series and other air-conditioner, it may be different from the ones showed above and refer to its engineering data for the details.

C: 1PA59889H