

CONTENTS

1. SAFETY CONSIDERATIONS.....	1
2. BEFORE INSTALLATION	2
3. SELECTING INSTALLATION SITE	3
4. PREPARATIONS BEFORE INSTALLATION.....	4
5. INDOOR UNIT INSTALLATION	4
6. REFRIGERANT PIPING WORK	5
7. DRAIN PIPING WORK.....	6
8. ELECTRIC WIRING WORK	7
9. WIRING EXAMPLE AND HOW TO SET THE REMOTE CONTROLLER.....	7
10. FIELD SETTING.....	10
11. TEST OPERATION.....	10

1. SAFETY CONSIDERATIONS

Please read these “SAFETY CONSIDERATIONS” carefully before installing air conditioning equipment and be sure to install it correctly. After completing the installation, make sure that the unit operates properly during the start-up operation. Please instruct the customer on how to operate the unit and keep it maintained.

Also, inform customers that they should store this installation manual along with the operation manual for future reference. This air conditioner comes under the term “appliances not accessible to the general public”.

Safety Precaution

This unit is a class A product. In a domestic environment this product may cause radio interference in which case the user may be required to take adequate measures.

Meaning of warning and caution symbols.

 **WARNING** Failure to observe a warning may result in death.

 **CAUTION** Failure to observe a caution may result in injury or damage to the equipment.

WARNING

- Ask your dealer or qualified personnel to carry out installation work. Do not try to install the machine yourself. Improper installation may result in water leakage, electric shocks or fire.
- Perform installation work in accordance with this installation manual. Improper installation may result in water leakage, electric shocks or fire.
- When installing the unit in a small room, take measures against to keep refrigerant concentration from exceeding allowable safety limits in the event of refrigerant leakage. Contact the place of purchase for more information. Excessive refrigerant in a closed ambient can lead to oxygen deficiency.
- Be sure to use only the specified accessories and parts for installation work. Failure to use the specified parts may result in water leakage, electric shocks, fire or the unit falling.
- Install the air conditioner on a foundation strong enough to withstand the weight of the unit. A foundation of insufficient strength may result in the equipment falling and causing injuries.

- Carry out the specified installation work after taking into account strong winds, typhoons or earthquakes. Improper installation work may result in the equipment falling and causing accidents.
- Make sure that a separate power supply circuit is provided for this unit and that all electrical work is carried out by qualified personnel according to local laws and regulations and this installation manual. An insufficient power supply capacity or improper electrical construction may lead to electric shocks or fire.
- Make sure that all wiring is secured, the specified wires and used, and no external forces act on the terminal connections or wires. Improper connections or installation may result in fire.
- When wiring the power supply and connecting the remote controller wiring and transmission wiring, position the wires so that the electric parts box lid can be securely fastened. Improper positioning of the electric parts box lid may result in electric shocks, fire or the terminals overheating.
- If the refrigerant gas leaks during installation, ventilate the area immediately. Toxic gas may be produced if the refrigerant gas comes into contact with fire.
- After completing the installation work, check that the refrigerant gas does not leak. Toxic gas may be produced if the refrigerant gas leaks into the room and comes into contact with a source of fire, such as a fan heater, stove or cooker.
- Before touching electrical parts, turn off the unit.

CAUTION

- Ground the air conditioner. Do not connect the ground wire to gas or water pipes, lightning rod or a telephone ground wire. Incomplete grounding may result in electric shocks.
- Be sure to install an earth leakage breaker. Failure to install an earth leakage breaker may result in electric shocks.
- While following the instructions in this installation manual, install drain piping in order to ensure proper drainage and insulate piping in order to prevent condensation. Improper drain piping may result in water leakage and property damage.
- Install the indoor and outdoor units, power supply wiring and connecting wires at least 1 meter away from televisions or radios in order to prevent image interference or noise. (Depending on the radio waves, a distance of 1 meter may not be sufficient enough to eliminate the noise.)
- Remote controller (wireless kit) transmitting distance can result shorter than expected in rooms with electronic fluorescent lamps. (inverter or rapid start types) Install the indoor unit as far away from fluorescent lamps as possible.
- Do not install the air conditioner in the following locations:
 - (a) where a mineral oil mist or an oil spray or vapor is produced, for example in a kitchen
Plastic parts may deteriorate and fall off or result in water leakage.
 - (b) where corrosive gas, such as sulfurous acid gas, is produced
Corroding copper pipes or soldered parts may result in refrigerant leakage.

- (c) near machinery emitting electromagnetic waves
Electromagnetic waves may disturb the operation of the control system and result in a malfunction of the equipment.
- (d) where flammable gases may leak, where there are carbon fiber or ignitable dust suspensions in the air, or where volatile flammables such as thinner or gasoline are handled.
Operating the unit in such conditions may result in fire.

2. BEFORE INSTALLATION

- When moving the unit while removing it from the carton box, be sure to lift it without exerting any pressure on other parts, especially, the refrigerant piping, drain piping, and other resin parts.
- Be sure to check the type of R410A refrigerant to be used before installing the unit. (Using an incorrect refrigerant will prevent normal operation of the unit.)
- The accessories needed for installation must be retained in your custody until the installation work is completed. Do not discard them!
- Decide upon a line of transport.
- Leave the unit inside its packaging while moving, until reaching the installation site. Where unpacking is unavoidable, use a sling of soft material or protective plates together with a rope when lifting, to avoid damage or scratches to the unit.
- For the installation of an outdoor unit, refer to the installation manual attached to the outdoor unit.
- Do not install or operate the unit in rooms mentioned below.
 - **Laden with mineral oil, or filled with oil vapor or spray like in kitchens. (Plastic parts may deteriorate which could eventually cause the unit to fall out of place, or could lead to leaks.)**
 - **Where corrosive gas like sulfurous gas exists. (Copper tubing and brazed spots may corrode, which could eventually lead to refrigerant leaks.)**
 - **Where exposed to combustible gases and where volatile flammable gas like thinner or gasoline is used. (Gas in the vicinity of the unit could ignite.)**
 - **Where machines can generate electromagnetic waves. (Control system may malfunction.)**
 - **Where the air contains high levels of salt such as that near the ocean and where voltage fluctuates greatly such as that in factories. Also in vehicles or vessels.**
- This unit, both indoor and outdoor, is suitable for installation in a commercial and light industrial environment.
If installed as a household appliance it could cause electromagnetic interference.

2-1 PRECAUTIONS

- Be sure to read this manual before installing the indoor unit.
- Entrust installation to the place of purchase or a qualified serviceman. Improper installation could lead to leaks and, in worse cases, electric shock or fire.
- Use only parts provided with the unit or parts satisfying required specifications. Unspecified parts could cause the unit to fall out of place, or could lead to leaks and, in worse cases, electric shock or fire.
- Ventilate the room if refrigerant gas leakage occurs during the installation work. Exposure gas to flame or hot object may result in production of toxic gases.
- When the installation work is finished, check to make certain that refrigerant gas is not leaking. Refrigerant gas leakage and its exposure to flame or hot object in fan heater, stove, cooking appliance, etc. may result in production of toxic gases.

2-2 ACCESSORIES

Check the following accessories are included with your unit.

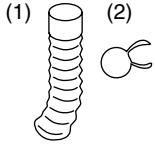
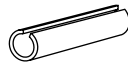
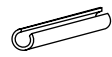
Name	Drain hose	Insulation for fitting
Quantity	1 set	1 each.
Shape	Hose × 1 Metal clamp × 1 	(3) For gas pipe  (4) For liquid pipe 

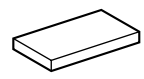
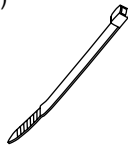
Name	Sealing pad	Clamp
Quantity	1 pc.	8 pcs.
Shape	(5) 	(6) 

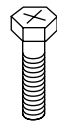
Name	Leveling	[Other] • Operation manual • Installation manual
Quantity	4 pcs.	
Shape	(7) 	

2-3 OPTIONAL ACCESSORIES

- These are two types of remote controllers: wired and wireless. Select a remote controller according to customer request and install in an appropriate place.

Table 1

Remote controller	
Wired type	
Wireless type	Heat pump type
	Cooling only type

NOTE

- If you wish to use a remote controller that is not listed in Table 1, select a suitable remote controller after consulting catalogs and technical materials.

FOR THE FOLLOWING ITEMS, TAKE SPECIAL CARE DURING CONSTRUCTION AND CHECK AFTER INSTALLATION IS FINISHED.

a. Items to be checked after completion of work

Items to be checked	If not properly done, what is likely to occur	Check
Are the indoor and outdoor unit fixed firmly?	The units may drop, vibrate or make noise.	
Is the gas leak test finished?	It may result in insufficient cooling.	
Is the unit fully insulated?	Condensate water may drip.	
Dose drainage flow smoothly?	Condensate water may drip.	
Dose the power supply voltage correspond to that shown on the name plate?	The unit may malfunction or the components burn out.	
Are wiring and piping correct?	The unit may malfunction or the components burn out.	
Is the unit safely grounded?	Dangerous at electric leakage.	
Is wiring size according to specifications?	The unit may malfunction or the components burn out.	
Is something blocking the air outlet or inlet of either the indoor or outdoor units?	It may result in insufficient cooling.	
Are refrigerant piping length and additional refrigerant charge noted down?	The refrigerant charge in the system is not clear.	

b. Items to be checked at time of delivery

Also review the "SAFETY CONSIDERATIONS"

Items to be checked	Check
Did you explain about operations while showing the instruction manual to your customer?	
Did you hand the instruction manual over to your customer?	

c. Points for explanation about operations

The items with **⚠ WARNING** and **⚠ CAUTION** marks in the instruction manual are the items pertaining to possibilities for bodily injury and material damage in addition to the general usage of the product. Accordingly, it is necessary that you make a full explanation about the described contents and also ask your customers to read the instruction manual.

2-4 NOTE TO THE INSTALLER

Be sure to instruct customers how to properly operate the unit (especially cleaning filters, operating different functions, and adjusting the temperature) by having them carry out operations themselves while looking at the manual.

3. SELECTING INSTALLATION SITE

(1) Select an installation site where the following conditions are satisfied and that meets with your customer's approval.

- Where the floor is strong enough to bear the indoor unit weight.
- Where the floor is not significantly inclined.
- Where nothing blocks the air passage.
- Where condensate can be properly drained.
- Where sufficient clearance for installation and maintenance can be ensured.
- Where optimum air distribution can be ensured.
- Where there is no risk of flammable gas leakage.
- Where piping between indoor and outdoor units is possible within the allowable limit. (Refer to the installation manual of the outdoor unit.)

⚠ CAUTION

- Install the indoor and outdoor units, power supply wiring and connecting wires at least 1 meter away from televisions or radios in order to prevent image interference or noise. (Depending on the radio waves, a distance of 1 meter may not be sufficient enough to eliminate the noise.)

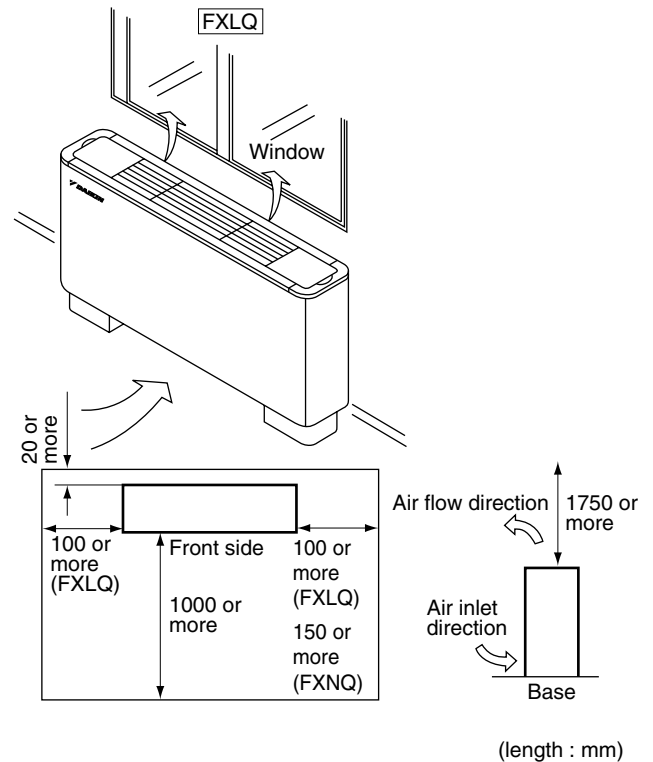

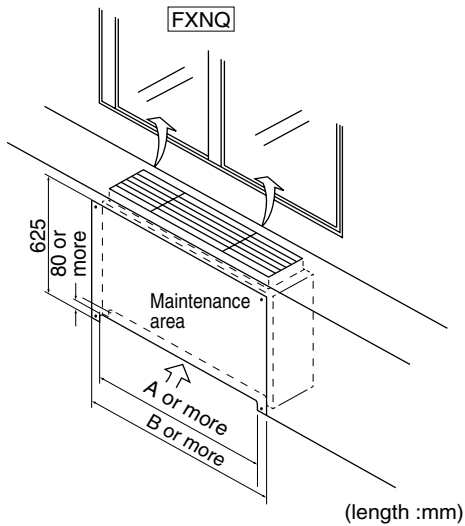

(IMPORTANT) Leave sufficient clearance for air inlet and maintenance.

Model		A (mm)	B (mm)
FXLQ20 · 25MVE	FXNQ20 · 25MVE	570	1030
FXLQ32 · 40MVE	FXNQ32 · 40MVE	710	1170
FXLQ50 · 63MVE	FXNQ50 · 63MVE	990	1450

4. PREPARATIONS BEFORE INSTALLATION

(1) Positioning of holes for fastening to the wall

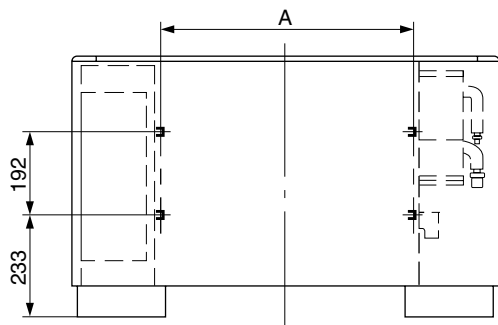

Model	A (mm)
FXNQ20 · 25MVE	590
FXNQ32 · 40MVE	730
FXNQ50 · 63MVE	1010

(2) How to open / close the front panel

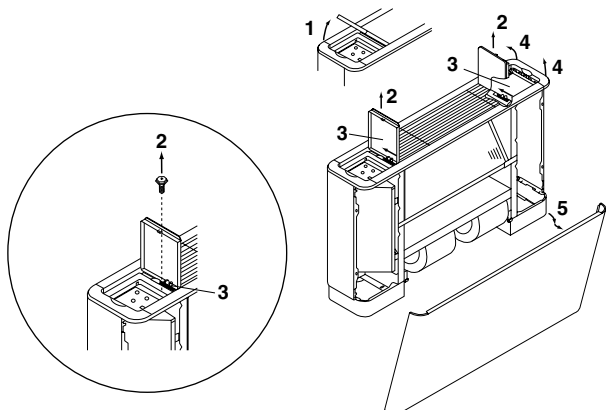

1. Open the lid of control panel (both left and right)
 2. Remove screws (both left and right) that lock the knobs in position.
 3. Push the knobs (both left and right) to the rear.
 4. Lift the front of the top plate.
 5. Lower the front panel towards the front of the unit.
- To close, perform the procedure in opposite order. Pull towards the front unit the knob snaps in place.

5. INDOOR UNIT INSTALLATION

As for the parts to be used for installation work, be sure to use the provided accessories and specified parts designated by our company.

- (1) Level the indoor unit with the leveling screws (7). If the floor is too uneven to level the unit, place the unit on a flat base and level.

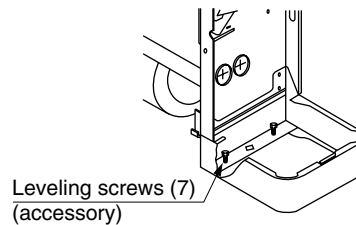

- (2) If the unit is in danger of falling over, either fasten to the wall using the holes provided, or fasten to the floor with an optional floor fastener.

- (3) The legs can be retracted if the indoor unit is to be hung on a wall. To do so, lift the legs as shown in the figure below.

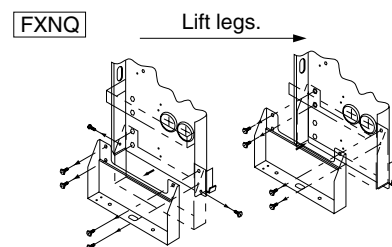
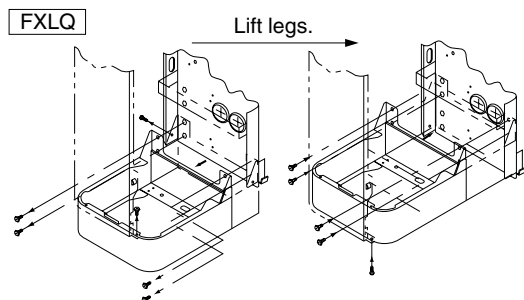

NOTES

1. Use the installation mount for installation. Check whether the wall is strong enough to bear the weight of the unit or not. If there is a risk, reinforce the wall before installing the unit.
2. The unit requires a minimum 100 mm clearance on the underside for air intake. Also, ensure the unit is level when installed so that drainage flows smoothly. If inclined, water can leak.
3. By a state of the wall, operating sound may become bigger.

(4) Use the following procedure to mount the remote controller (optional accessory) on the unit is so desired. (FXLQ type only)

- Open the left side lid of control panel and mount the lower case on the remote controller.

NOTE

See the accessory instruction procedure for instructions on screw fastening and wiring for the remote controller.

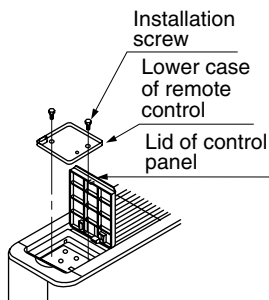

CAUTION

Setting the unit at an angle opposite to the drain piping might cause leaks.

6. REFRIGERANT PIPING WORK

⟨For refrigerant piping of outdoor units, see the installation manual attached to the outdoor unit.⟩

⟨Execute heat insulation work completely on both sides of the gas piping and the liquid piping. Otherwise, a water leakage can result sometimes.⟩

(When using a heat pump, the temperature of the gas piping can reach up to approximately 120°C, so use insulation which is sufficiently resistant.)

⟨Also, in cases where the temperature and humidity of the refrigerant piping sections might exceed 30°C or RH80%, reinforce the refrigerant insulation. (20 mm or thicker) Condensation may form on the surface of the insulating material.⟩

⟨Before refrigerant piping work, check which type of refrigerant is used. Proper operation is not possible if the types of refrigerant are not the same.⟩

CAUTION

- Use a pipe cutter and flare suitable for the type of refrigerant.
- Apply ester oil or ether oil around the flare portions before connection.
- To prevent dust, moisture or other foreign matter from infiltrating the tube, either pinch the end or cover it with tape.
- Do not allow anything other than the designated refrigerant to get mixed into the refrigerant circuit, such as air, etc. If any refrigerant gas leaks while working on the unit, ventilate the room thoroughly right away.

- Do not allow air, etc., to become mixed with the specified refrigerant inside the refrigeration cycle.
- The outdoor unit is charged with refrigerant.
- Be sure to use both a spanner and torque wrench together, as shown in the drawing, when connecting or disconnecting pipes to/from the unit.
- To prevent flare nut cracking and gas leaks, be sure to use both a spanner and torque wrench together, as shown in the drawing, when connecting or disconnecting pipes to / from the unit.
- Refer to Table 2 for the dimensions of flare nut spaces.

- When connecting the flare nut, coat the flare section (both inside and outside) with ester oil or ether oil, rotate three or four times first, then screw in.
- Refer to the Table 2 for tightening torque.
- Wrap only the gas line side with the sealing pad (5). Bend the pad over the insulation for fitting (union) from above.
- After inspecting pipe joints for gas leakage, be sure to insulate with the accessory joint insulation for fitting (3) (4) while referring to the figure on the next page. (Fasten both ends with clamps (6)).

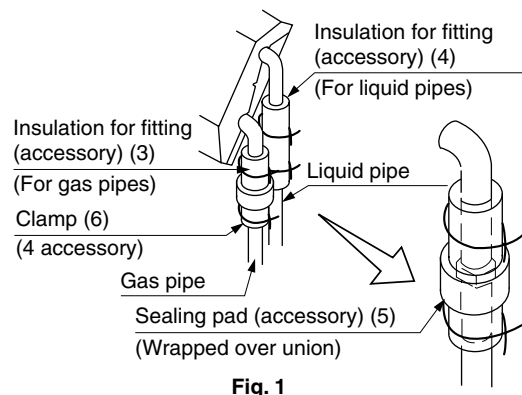
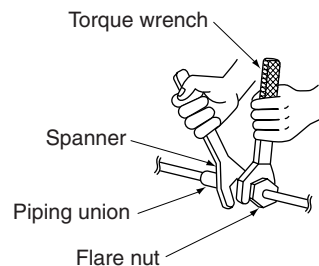
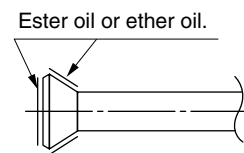

Fig. 1

CAUTION

Setting the unit at an angle opposite to the drain piping might cause leaks.

Use “Tabel 3” as a reference if a torque wrench is not available. Once work is complete, make sure there is no gas leaking. As the flare nut is tightened with the wrench, the torque will suddenly increase. From that position, tighten the nut to the angle shown on “Tabel 3”.

- Make absolutely sure to execute heat insulation works on the pipe-connecting section after checking gas leakage by thoroughly studying the following figure and using the attached heat insulating materials for fitting (3) and (4). (Fasten both ends with the clamps (6) (accessory).) **(Refer to Fig. 1)**
- Wrap the sealing pad (5) (accessory) only around the insulation for the joints on the gas piping side.

CAUTION

Be sure to insulate any field piping all the way to the piping connection inside the unit. Any exposed piping may cause condensation or burns if touched.

CAUTION

CAUTION TO BE TAKEN WHEN BRAZING REFRIGERANT PIPING

Do not use flux when brazing refrigerant piping. Therefore, use the phosphor copper brazing filter metal (BCuP) which does not require flux.
(Flux has extremely harmful influence on refrigerant piping systems. For instance, if the chlorine based flux is used, it will cause pipe corrosion or, in particular, if the flux contains fluorine, it will damage the refrigerant oil.)

- Before brazing local refrigerant piping, nitrogen gas shall be blown through the piping to expel air from the piping. If your brazing is done without nitrogen gas blowing, a large amount of oxide film develops inside the piping, and could cause system malfunction.
- When brazing the refrigerant piping, only begin brazing after having carried out nitrogen substitution or while inserting nitrogen into the refrigerant piping. Once this is done, connect the indoor unit with a flared or a flanged connection.
- Nitrogen should be set to 0.02 Mpa (0.2 kg/cm²) with a pressure-reducing valve if brazing while inserting nitrogen into the piping.

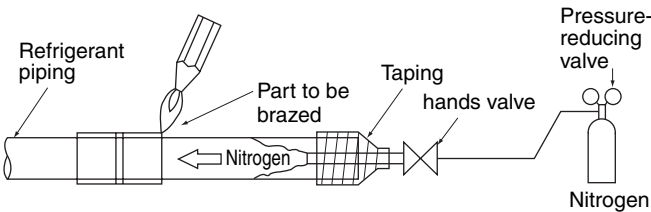

NOTE

The flare nuts used must be those included with the main body.

- Refer to Table 2 for tightening torque.

Table 2

Pipe size	Tightening torque	Flare dimensions A (mm)	Flare shape
φ 6.4 (1/4")	14.2 – 17.2N·m (144 – 176 kgf·cm)	8.7 – 9.1	
φ 9.5 (3/8")	32.7 – 39.9N·m (333 – 407 kgf·cm)	12.8 – 13.2	
φ 12.7 (2/1")	49.5 – 60.3N·m (504 – 616 kgf·cm)	16.2 – 16.6	
φ 15.9 (5/8")	61.8 – 75.4N·m (630 – 770 kgf·cm)	19.3 – 19.7	

Not recommendable but in case of emergency

You must use a torque wrench but if you are obliged to install the unit without a torque wrench, you may follow the installation method mentioned below.

After the work is finished, make sure to check that there is no gas leak.

When you keep on tightening the flare nut with a spanner, there is a point where the tightening torque suddenly increases. From that position, further tighten the flare nut the angle shown below:

Table 3

Pipe size	Further tightening angle	Recommended arm length of tool
φ 6.4 (1/4")	60 to 90 degrees	Approx. 150mm
φ 9.5 (3/8")	60 to 90 degrees	Approx. 200mm
φ 12.7 (1/2")	30 to 60 degrees	Approx. 250mm
φ 15.9 (5/8")	30 to 60 degrees	Approx. 300mm

7. DRAIN PIPING WORK

⟨⟨Rig the drain pipe as shown below and take measures against condensation. Improperly rigged piping could lead to leaks and eventually wet furniture and belongings.⟩⟩

- (1) Carry out the drain piping

Connect the drain hose (1) using the attached hose and parts, as shown in the right drawing.

Piping process inside unit

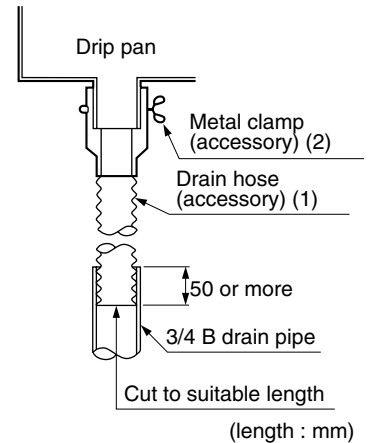
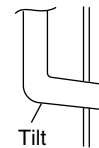

- If converging multiple drain pipes, install according to the procedure shown below.

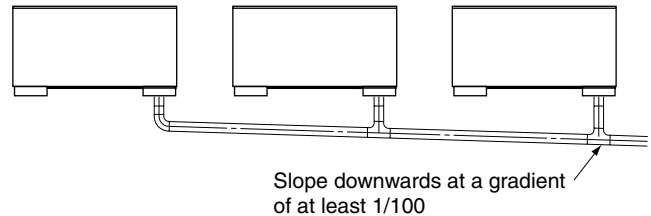

Select converging drain pipes whose gauge is suitable for the operating capacity of the unit.

- (2) After piping work is finished, check drainage flows smoothly.
 - Add approximately 1 liter of water slowly from the air outlet and check drainage flow.
- (3) Be sure to insulate all indoor pipes



CAUTION

- Drain piping connections
Do not connect the drain piping directly to sewage pipes that smell of ammonia. The ammonia in the sewage might enter the indoor unit through the drain pipes and corrode the heat exchanger.
- Keep in mind that it will become the cause of getting drain pipe blocked if water collects on drain pipe.

8. ELECTRIC WIRING WORK

8-1 GENERAL INSTRUCTIONS

- All field supplied parts and materials, electric works conform to local codes.
- Use copper wire only.
- Follow the "WIRING DIAGRAM" attached to the unitbody to wire the outdoor unit, indoor units and the remote controller. For details on hooking up the remote controller, refer to the "INSTALLATION MANUAL OF REMOTE CONTROLLER."
- All wiring must be performed by an authorized electrician.
- This system consists of multiple indoor units. Mark each indoor unit as unit A, unit B . . . , and be sure the terminal board wiring to the outdoor unit and BS unit are properly matched. If wiring and piping between the outdoor unit and an indoor unit are mismatched, the system may cause a malfunction.
- A circuit breaker capable of shutting down the power supply to the entire system must be installed.
- Refer to the installation manual attached to the outdoor unit for the size of power supply wiring connected to the outdoor unit, the capacity of the circuit breaker and switch, and wiring instructions.
- Be sure to ground the air conditioner.
- Do not connect the ground wire to gas and water pipes, lightning rods, or telephone ground wires.
 - Gas pipes : might cause explosions or fire if gas leaks.
 - Water pipes : no grounding effect if hard vinyl piping is used.
 - Telephone ground wires or lightning rods : might cause abnormally high electric potential in the ground during lightning storms.

8-2 ELECTRICAL CHARACTERISTICS

Units				Power supply		Fan motor	
Model	Hz	Volts	Voltage range	MCA	MFA	kW	FLA
FXLQ20 · 25MVE, FXNQ20 · 25MVE	50	220-240	Max. 264 Min. 198	0.3	15	0.015	0.2
FXLQ32 · 40MVE, FXNQ32 · 40MVE				0.6	15	0.025	0.5
FXLQ50 · 63MVE, FXNQ50 · 63MVE				0.6	15	0.035	0.5
FXLQ20 · 25MVE, FXNQ20 · 25MVE	60	220	Max. 242 Min. 198	0.3	15	0.015	0.2
FXLQ32 · 40MVE, FXNQ32 · 40MVE				0.5	15	0.025	0.4
FXLQ50 · 63MVE, FXNQ50 · 63MVE				0.6	15	0.035	0.5

MCA: Min. Circuit Amps (A); MFA: Max. Fuse Amps (A)
kW: Fan Motor Rated Output (kW); FLA: Full Load Amps (A)

8-3 SPECIFICATIONS FOR FIELD SUPPLIED FUSES AND WIRE

Model	Power supply wiring			Remote controller wiring Transmission wiring	
	Field fuses 	Wire	Size	Wire	Size
FXLQ20 · 25 · 32 · 40 · 50 · 63MVE	15A	H05VV -U3G	Size must comply with local codes.	Sheathed wire (2 wire)	0.75 - 1.25 mm ²
FXNQ20 · 25 · 32 · 40 · 50 · 63MVE					

NOTE

1. Allowable length of transmission wiring between indoor / outdoor units and between the indoor unit and the remote controller is as follows.
 - (1) Outdoor unit – Indoor unit:
Max. 1000 m (Total wiring length: 2000 m)
 - (2) Indoor unit – Remote controller:
Max. 500 m

9. WIRING EXAMPLE AND HOW TO SET THE REMOTE CONTROLLER

9-1 HOW TO CONNECT WIRINGS

- Remove the electric parts box lid and connect the wiring.

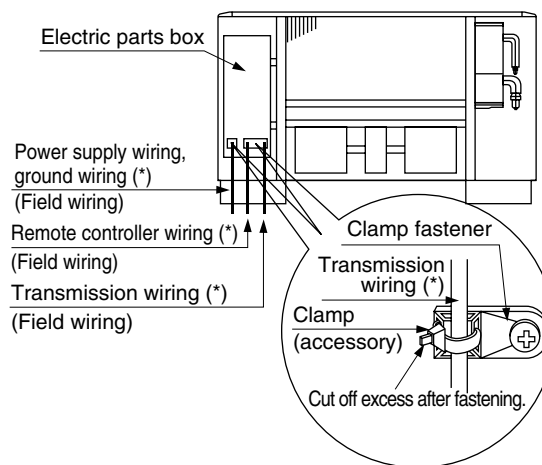

NOTE

- For electric parts box wiring, also see "Electric Wiring Diagram" label.
- Remote controller wiring, transmission wiring
Do not confuse the two when connecting to the terminal block for remote controller.
- Fasten the wiring with accessory clamp (6).
- If mounting a remote controller on the unit, wire as shown in the figure on the right.

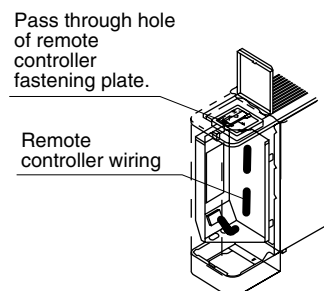

- If wiring from the piping side, wire as shown in the figure below.

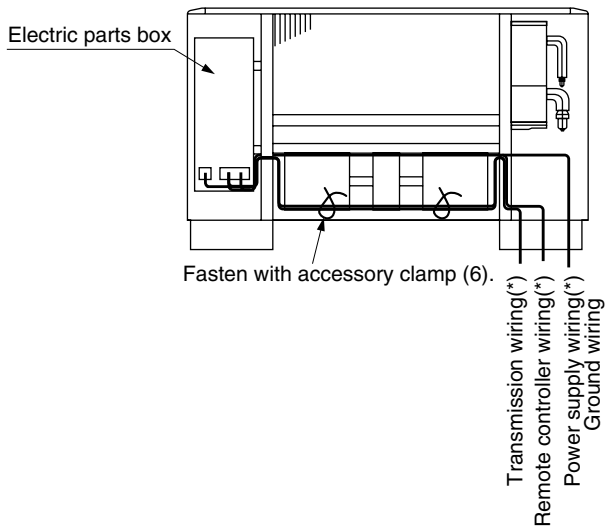
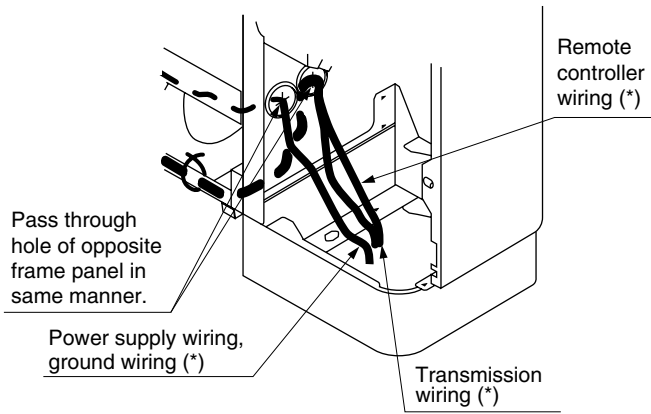

CAUTION

- Be sure to attach the sealing material or putty (field supplied) to hole of wiring to prevent the infiltration of water as well as any insects and other small creatures from outside. Otherwise a short-circuit may occur inside the electric parts box.
- When clamping the wires, be sure no pressure is applied to the wire connections by using the included clamping material to make appropriate clamps. Also, when wiring, make sure the lid on the electric parts box fits snugly by arranging the wires neatly and attaching the electric parts box lid firmly. When attaching the electric parts box lid, make sure no wires get caught in the edges. Pass wiring through the wiring through holes to prevent damage to them.
- Make sure the remote controller wiring, the wiring between the units, and other electrical wiring do not pass through the same locations outside of the unit, separating them by at least 50mm, otherwise electrical noise (external static) could cause mistaken operation or breakage.

[PRECAUTIONS]

1. Use round crimp-style terminals for connecting wires to the power supply terminal block.
If unavailable, observe the following points when wiring.
 - Do not connect wires of different gauge to the same power supply terminal.
(Looseness in the connection may cause overheating.)
 - Use the specified electric wire. Connect the wire securely to the terminal. Lock the wire down without applying excessive force to the terminal. (Tightening torque: 131N·cm ±10 %)

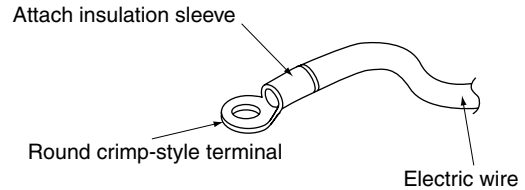

2. Tightening torque for the terminal screws.

- Use the correct screwdriver for tightening the terminal screws. If the blade of screwdriver is too small, the head of the screw might be damaged, and the screw will not be properly tightened.
- If the terminal screws are tightened too hard, screws might be damaged.
- Refer to the table below for the tightening torque of the terminal screws.

Terminal	Size	Tightening torque
Terminal block for remote controller (6P)	M3.5	0.79 – 0.97N·m
Power supply terminal block (2P)	M4	1.18 – 1.44N·m
Ground terminal	M4	1.44 – 1.94N·m

3. Do not connect wires of different gauge to the same grounding terminal. Looseness in the connection may deteriorate protection.
4. Outside of the unit, keep transmission wiring at least 50 mm away from power supply wiring. The equipment may malfunction if subjected to electrical (external) noise.
5. For remote controller wiring, refer to the "INSTALLATION MANUAL OF REMOTE CONTROLLER".
6. **Never connect power supply wiring to the terminal block for remote controller wiring. A mistake of the sort could damage the entire system.**
7. Use only specified wire and tightly connect wires to terminals. Be careful wires do not place external stress on terminals. Keep wiring in neat order and so as not to obstruct other equipment such as popping open the electric parts box lid. Make sure the lid closes tight. Incomplete connections could result in overheating, and in worse case, electric shock or fire.

9-2 WIRING EXAMPLE

- Fit the power supply wiring of each unit with a switch and fuse as shown in the drawing.

COMPLETE SYSTEM EXAMPLE (3 SYSTEMS)

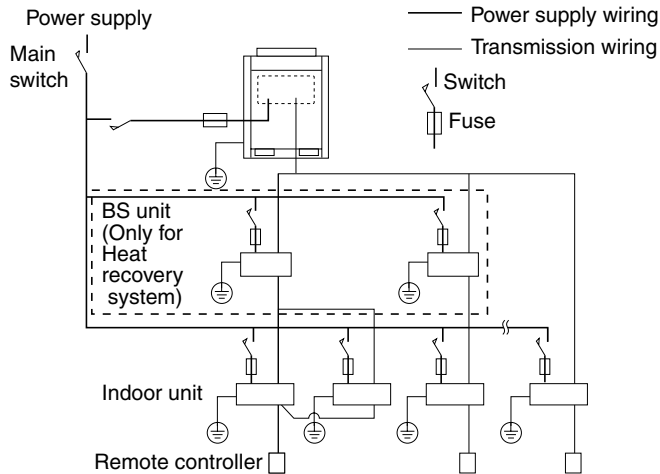

1. When using 1 remote controller for 1 indoor unit. (Normal operation)

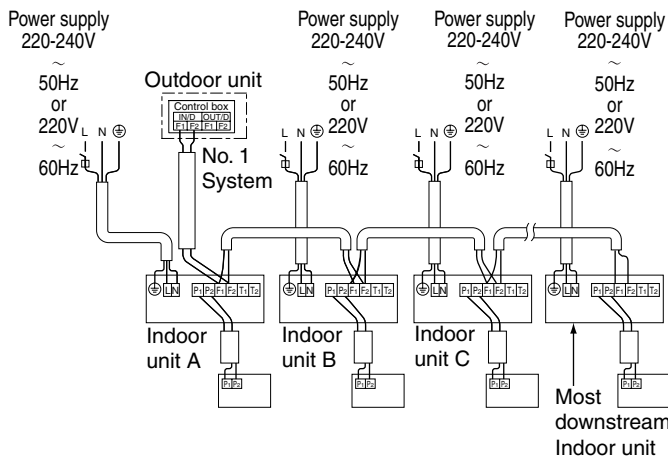

2. For group control or use with 2 remote controllers

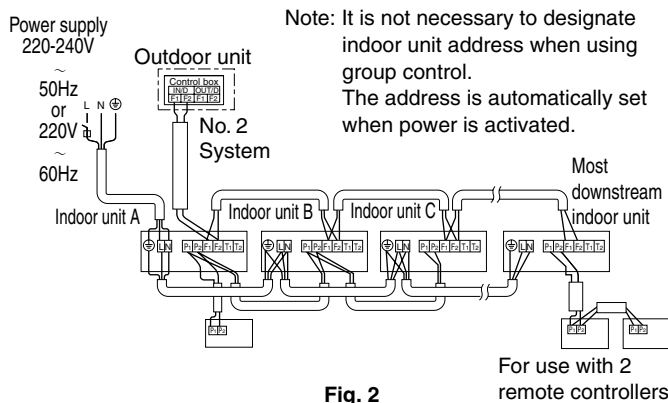
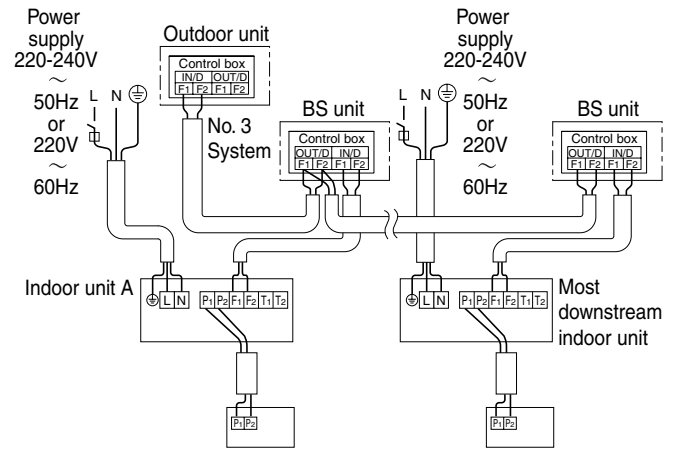

Fig. 2

3. When including BS unit



[PRECAUTIONS]

- A single switch can be used to supply power to units on the same system. However, branch switches and branch circuit breakers must be selected carefully.
- Do not ground the equipment on gas pipes, water pipes or lightning rods, or crossground with telephones. Improper grounding could result in electric shock.

9-3 CONTROL BY 2 REMOTE CONTROLLERS (Controlling 1 indoor unit by 2 remote controllers)

- When using 2 remote controllers, one must be set to "MAIN" and the other to "SUB".

MAIN/SUB CHANGEOVER

- Insert a \ominus screw driver into the recess between the upper and lower part of remote controller and, working from the 2 positions, pry off the upper part. The remote controller PC board is attached to the upper part of remote controller.

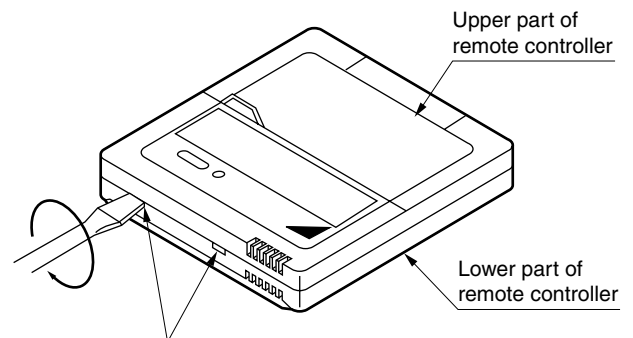

Insert the screwdriver here and gently work off the upper part of remote controller.

- Turn the MAIN/SUB changeover switch on one of the two remote controllers PC board to "S". (Leave the switch of the other remote controller set to "M".)

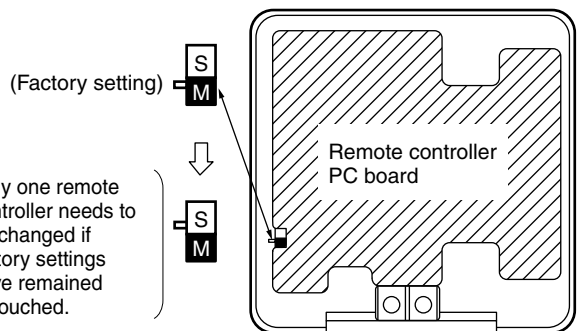

Wiring Method (See “ELECTRIC WIRING WORK”)

- (3) Remove the electric parts box lid
- (4) **Add remote control 2 (slave) to the terminal block for remote controller (P₁, P₂) in the terminal box.**
(There is no polarity.) (Refer to Fig. 2 and 8-3.)

9-4 COMPUTERISED CONTROL (FORCED OFF AND ON/OFF OPERATION)

(1) Wire specifications and how to perform wiring

- Connect input from outside to terminals T1 and T2 of the terminal block for remote controller.

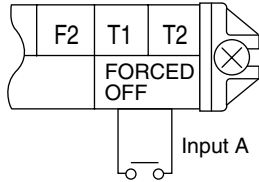

Wire specification	Sheathed vinyl cord or cable (2 wire)
Gauge	0.75 - 1.25 mm ²
Length	Max. 100 m
External terminal	Contact that can ensure the minimum applicable load of 15 V DC, 10 mA.

(2) Actuation

- The following table explains FORCED OFF and ON/OFF OPERATIONS in response to input A.

FORCED OFF	ON/OFF operation
Input “ON” stops operation (impossible by remote controllers).	Input OFF → ON turns ON unit.
Input OFF enables control by remote controller.	Input ON → OFF turns OFF unit.

(3) How to select FORCED OFF and ON/OFF

- Turn the power on and then use the remote controller to select operation.

9-5 CENTRALIZED CONTROL

- For centralized control, it is necessary to designate the group No. For details, refer to the manual of each optional controllers for centralized control.

10. FIELD SETTING

Make sure the electric parts box lids are closed on the indoor and outdoor units.

Field setting must be made from the remote controller in accordance with the installation condition.

- Setting can be made by changing the “Mode No.,” “FIRST CODE NO.,” and “SECOND CODE NO.”.
- For setting and operation, refer to the “FIELD SETTING” in the installation manual of the remote controller.

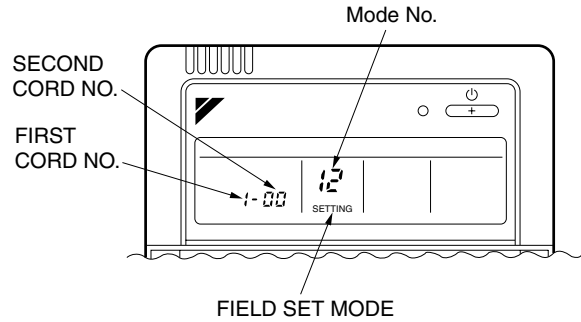

- Set the remote controller to the field set mode. For details, refer to the “HOW TO SET IN THE FIELD”, in the remote controller manual.
- When in the field set mode, select mode No. 12, then set the first code (switch) No. to “1”. Then set second code (position) No. to “01” for FORCED OFF and “02” for ON / OFF OPERATION. (FORCED OFF at factory set)

11. TEST OPERATION

Refer to the installation manual of the outdoor unit.

- The operation lamp of the remote controller will flash when an malfunction occurs. Check the malfunction code on the liquid crystal display to identify the point of trouble. An explanation of malfunction codes and the corresponding trouble is provided in “CAUTION FOR SERVICING” of the outdoor unit. If any of the items in Table 4 are displayed, there may be a problem with the wiring or power, so check the wiring again.

Table 4

Remote control display	Content
“Concentrated Management” is lit up	<ul style="list-style-type: none"> • There is a short circuit at the FORCED OFF terminals (T1, T2)
“U4” is lit up “UH” is lit up	<ul style="list-style-type: none"> • The power on the outdoor unit is off. • The outdoor unit has not been wired for power supply. • Incorrect wiring for the transmission wiring and / or FORCED OFF wiring.
No display	<ul style="list-style-type: none"> • The power on the indoor unit is off. • The indoor unit has not been wired for power supply. • Incorrect wiring for the remote controller wiring, the transmission wiring and / or the FORCED OFF wiring.