

technical data

BS box
BSVQ-MV1

air conditioning systems

R-410A

VRV[®]-WII

2b

TABLE OF CONTENTS

BS box

1	Specifications	2
	Technical specifications	2
	Electrical specifications	2
	Safety device settings	2
2	Accessories	2
3	Dimensions.....	3
	Dimensional drawings	3
	Centre of gravity	4
4	Piping diagram.....	5
5	Wiring diagram.....	6

1 Specifications

1 - 1 Technical specifications

BSVQ-MV1			100	160	250
TOTAL CAPACITY INDEX OF CONNECTABLE INDOOR UNIT			≤ 100	100 < X ≤ 160	160 < X ≤ 250
MAXIMUM NUMBER OF CONNECTABLE INDOOR UNITS			5	8	5
NOMINAL INPUT	Cooling	W	21	21	21
	Heating	W	21	21	21
DIMENSIONS			mm 185x310x280		
WEIGHT			kg 9 9 10		
CASING			galvanised steel plate		
PIPING CONNECTIONS	Indoor unit	Liquid	mm 9.5 (flare) *1	9.5 (flare)	9.5 (flare)
		Gas	mm 15.9 (flare) *1	15.9 (flare)	22.2 (flange) *2
	Outdoor unit	Liquid	mm 9.5 (flare) *1	9.5 (flare)	9.5 (flare)
		Suction gas	mm 15.9 (flare) *1	15.9 (flare)	22.2 (flange) *2
		Discharge gas	mm 12.7 (flare) *1	12.7 (flare)	19.1 (brazing) *3
SOUND ABSORBING THERMAL INSULATION MATERIAL			flame and heat resistant foamed polyethylene		

4D042118/19/20

NOTES

- If the total capacity of all indoor units connected to the system is less than 7,1kW, connect the attached pipe to the field pipe. (Brazing the connection between the attached pipe and the field pipe)
- Use the field flanged pipe. Also with a 200 class indoor unit, connect the attached reducer to the field pipe. (Brazing the connection between the attached pipe and field pipe)
- Use the attached pipe
- Information was not available at the time of publication
- Please note that connectable indoor unit for BSVQ250M is from size 50 onwards. This means that indoor size 20 to 40 should NOT be connected to BSVQ250M. The explanation of possible trouble is that there is mainly a problem with the refrigerant side: if only this BSVQ is in heating, and all the other BSVQ are in cooling, there is a high risk of liquid back to the suction side (by insufficient evaporation of liquid used for extra sub-cool). If such operation of BSVQ250M runs for a while with an indoor thermostat-on of index 40 or less, it can result in compressor failure. The communication itself will work as the BSVQ does not know its size, so it can not check if indoor index is correct or not.
- BS boxes cannot be installed upside down
- In case of sound sensitive application, please contact your local daikin representative for more details and recommendations**

1 - 2 Electrical specifications

BSVQ-MV1			100	160	250
CURRENT	Minimum circuit amps (MCA)	A	0.2		
	Maximum fuse amps (MFA)	A	15		
POWER SUPPLY			V1 1~, 50Hz, 220-240V		
VOLTAGE RANGE			Min ~ Max 198 ~ 264		

4D042568

NOTES

- Voltage range: units are suitable for use on electrical systems where voltage supplied to units terminals is not below or above listed range limits.
- Maximum allowable voltage unbalance between phases is 2 %
- MCA / MFA:
MCA = 1.25 x FLA
MFA ≤ 4 x FLA
(Next lower standard fuse rating. Min. 15A)
- Select wire size based on the MCA
- Instead of fuse, use circuit breaker
- For more details concerning conditional connections, see <http://www.daikineurope.com/extranet>, select "Daikin Documentation" and select "conditional connection", "the requested product type" and "English" from the drop down lists, click the search button. Finally, click on the document title of your choice.

1 - 3 Safety device settings

BSVQ-MV1			100	160	250
PC BOARD FUSE			250V, 5A		

4D042569

2 Accessories

BSVQ-MV1			100	160	250
COOL/HEAT SELECTOR			KRC19-26A		
FIXING BOX			KJB111A		

3 Dimensions

3 - 1 Dimensional drawings

BSVQ100,160MV1

Technical drawing showing dimensions for the BSVQ100,160MV1 unit. Key dimensions include: suspension bolt pitch (350), (181) on both sides, (170) for suspension bracket pitch, (300) servicing space, (450) inspection door, (185) height, (164) and (176) width offsets, (310) total width, (75) height offset, (140) and (35) bottom offsets, (85) and (45) top offsets, (60) and (70) internal offsets, (10) and (70) bottom offsets, (210) total bottom offset, (60) and (61) electric box height, (300more) and (100more) servicing space for detail views, and (450) inspection door for electric box detail.

Nr	Part name	Description
1	Suction gas pipe connection port	ø 15.9 Flare connection
2	Discharge gas pipe connection port	ø 12.7 Flare connection
3	Liquid pipe connection port	ø 9.5 Flare connection
4	Gas pipe connection port	ø 15.9 Flare connection
5	Liquid pipe connection port	ø 9.5 Flare connection
6	Electric box (note 1.)	
7	Suspension brackets	
8	Grounding terminal	M4

NOTES

- Electric box can also be fixed on the other side of the unit.
- Be sure to install an inspection door at electric box side.
- Install a servicing space in the bottom of electric

3D042464A

BSVQ250MV1

Technical drawing showing dimensions for the BSVQ250MV1 unit. Key dimensions include: suspension bolt pitch (350), (290) and (376) total widths, (286) and (165) offsets, (170) for suspension bracket pitch, (300) servicing space, (450) inspection door, (185) height, (164) and (181) width offsets, (310) total width, (75) height offset, (140) and (35) bottom offsets, (85) and (45) top offsets, (60) and (70) internal offsets, (10) and (70) bottom offsets, (210) total bottom offset, (60) and (61) electric box height, (450more) and (100more) servicing space for detail views, and (550more) servicing space for electric box detail.

Nr	Part name	Description
1	Suction gas pipe connection port	ø 22.2 Flange connection
2	Discharge gas pipe connection port	ø 19.1 Flare connection
3	Liquid pipe connection port	ø 9.5 Flare connection
4	Gas pipe connection port	ø 22.2 Flange connection
5	Liquid pipe connection port	ø 9.5 Flare connection
6	Electric box (Note 1)	
7	Suspension brackets	
8	Grounding terminal	M 4
9	Attached pipe (1)	ø 22.2 Brazing connection
0	Attached pipe (2) (Note 3)	ø 19.1 Brazing connection
1	Attached pipe (3)	ø 19.1 Brazing connection

NOTES

- Electric box can also be fixed on the other side of the unit.
- Be sure to install an inspection door at electric

3D042465A

3 Dimensions

3 - 2 Centre of gravity

BSVQ100,160MV1

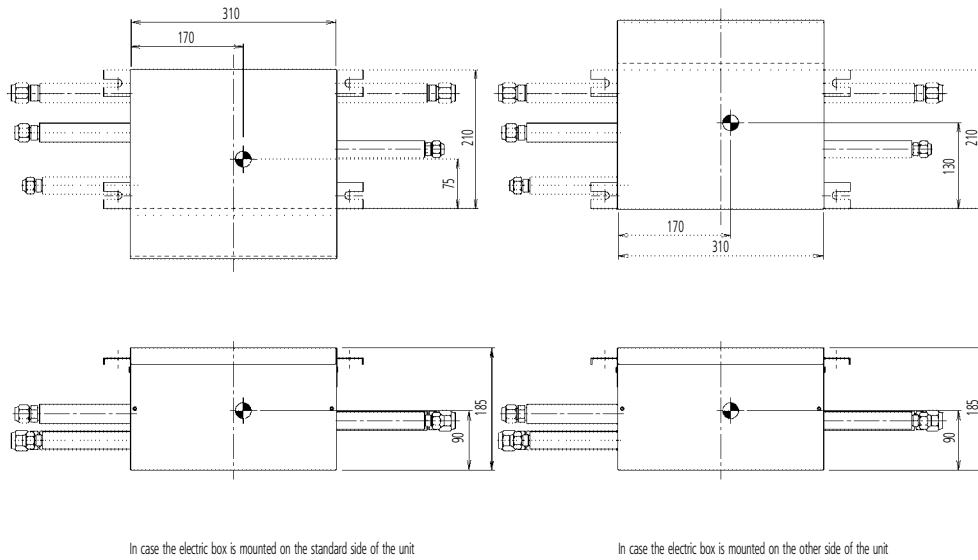

4D042509

BSVQ250MV1

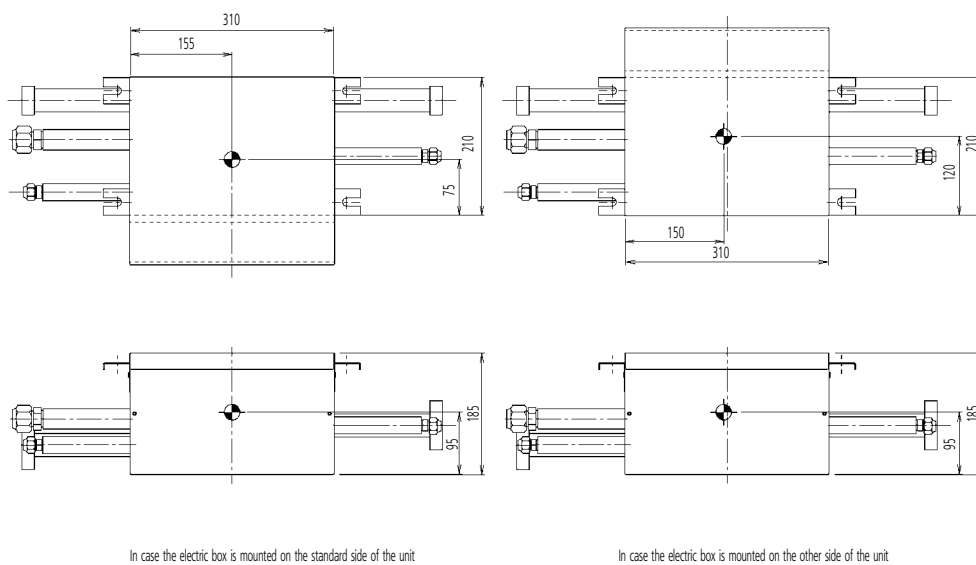

4D042511

4 Piping diagram

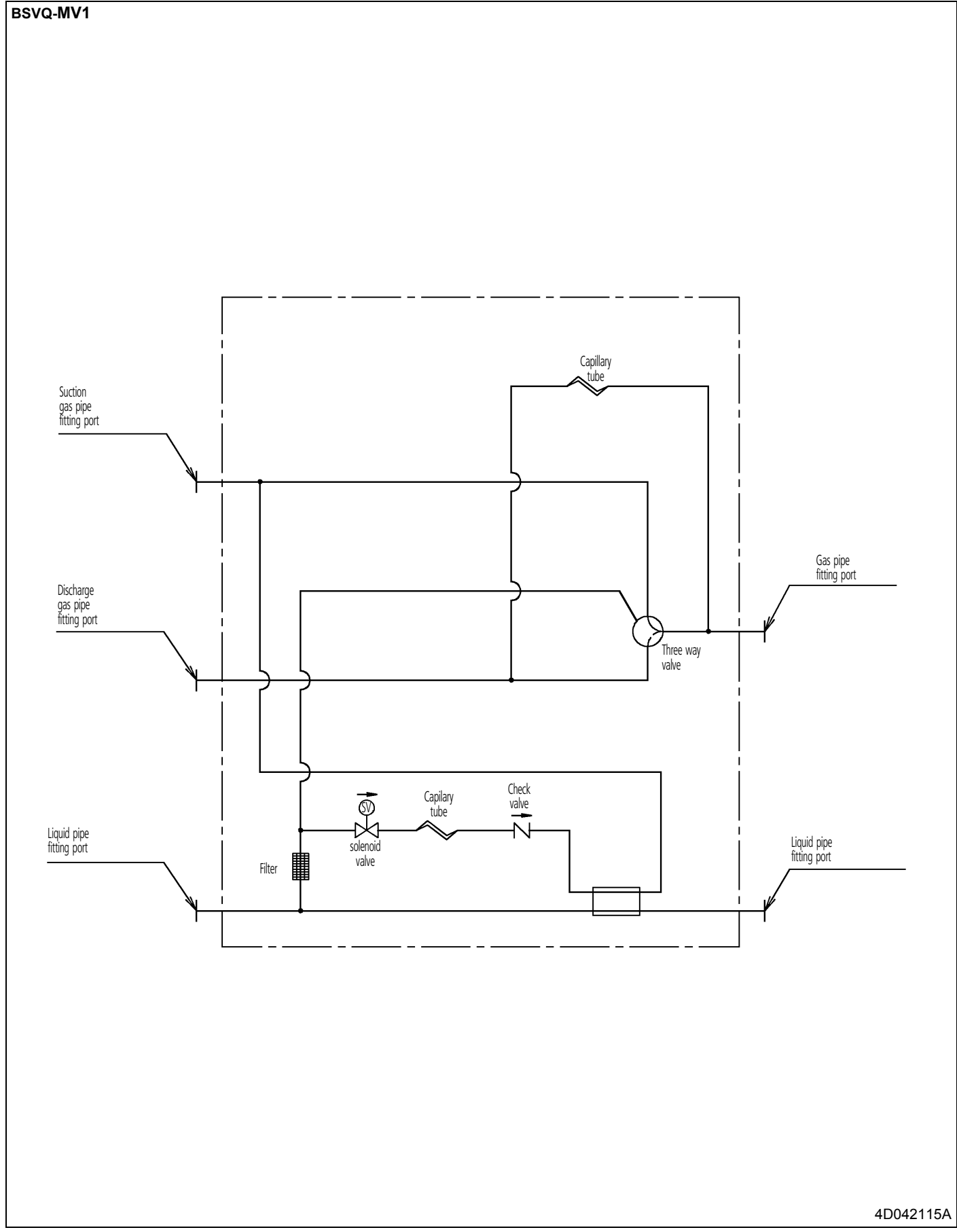

5 Wiring diagram

BSVQ-MV1

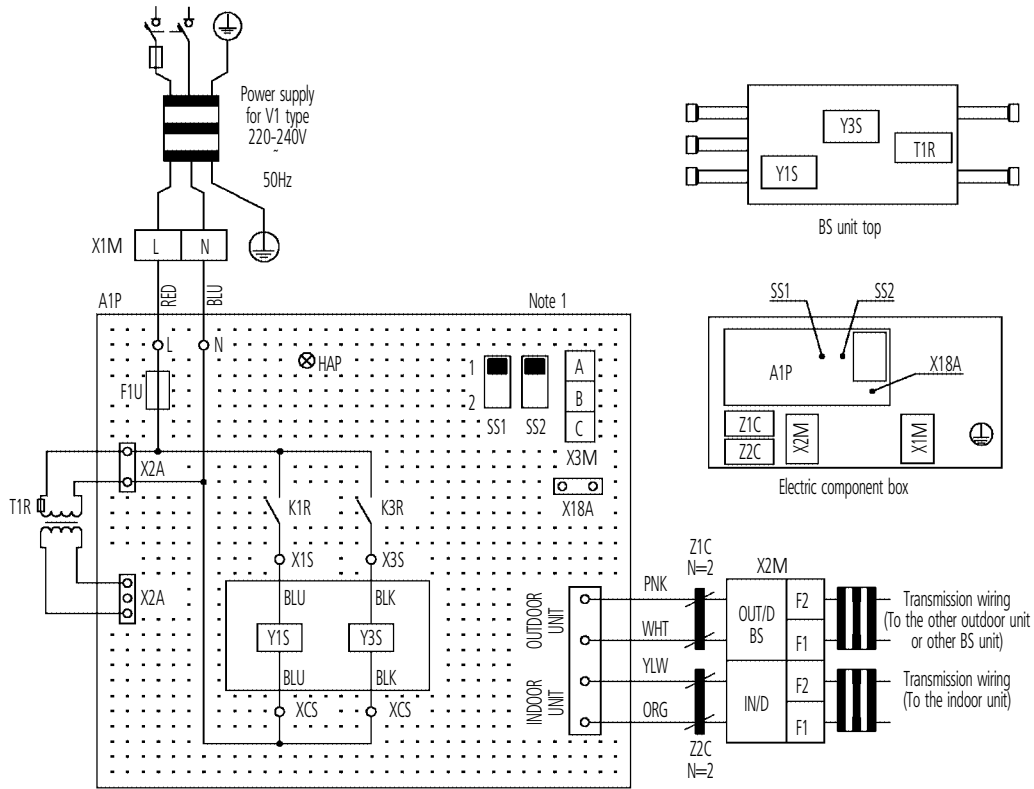

L-RED	N-BLUE				
A1P	Printed circuit board	T1R	Transformer (220-240V/20V)	Y3S	4 way valve (Discharge line)
F1U	Fuse (B, 250V, 5A.)	X1M	Terminal strip (Power)	X18A	Connector for optional parts
HAP	Light emitting diode (Service monitor-green)	X2M	Terminal strip (Control)		Connector (Wiring external control adaptor for outdoor unit)
K1R, 3R	Magnetic relay	X3M	Terminal strip (C/H Selector)		
SS1, 2	Selector switch (Selection of remote controller)	Y1S	Solenoid valve (Liquid line)	Z1C, 2c	Noise filter (Ferite core)

- : Field wiring
- : Connector
- : Wire clamp
- : Terminal

COLORS : BLK : Black ORG : Orange
 BLU : Blue RED : Red
 PNK : Pink WHT : White
 YLW : Yellow

NOTES

1 When using the cool/heat selector (optional accessory), connect it to terminals A, band C on X3M (A1P).
 In the case, set the selector switch SS1 & SS2 on the A1P according to below

drawing.



2 As for wiring to the IN/D F1&F2 and OUT/D, BS F1&F2 on X2M, refer to

2b

VRV-WII



In all of us,
a green heart

Daikin's unique position as a manufacturer of air conditioning equipment, compressors and refrigerants has led to its close involvement in environmental issues. For several years Daikin has had the intension to become a leader in the provision of products that have limited impact on the environment. This challenge demands the eco design and development of a wide range of products and an energy management system, resulting in energy conservation and a reduction of waste.



Daikin Europe N.V. is approved by LRQA for its Quality Management System in accordance with the ISO9001 standard. ISO9001 pertains to quality assurance regarding design, development, manufacturing as well as to services related to the product.



ISO14001 assures an effective environmental management system in order to help protect human health and the environment from the potential impact of our activities, products and services and to assist in maintaining and improving the quality of the environment.



Daikin units comply with the European regulations that guarantee the safety of the product.

VRV® products are not within the scope of the Eurovent certification programme.

The present publication is drawn up by way of information only and does not constitute an offer binding upon Daikin Europe N.V.. Daikin Europe N.V. has compiled the content of this publication to the best of its knowledge. No express or implied warranty is given for the completeness, accuracy, reliability or fitness for particular purpose of its content and the products and services presented therein. Specifications are subject to change without prior notice. Daikin Europe N.V. explicitly rejects any liability for any direct or indirect damage. In the broadest sense, arising from or related to the use and/or interpretation of this publication. All content is copyrighted by Daikin Europe N.V..

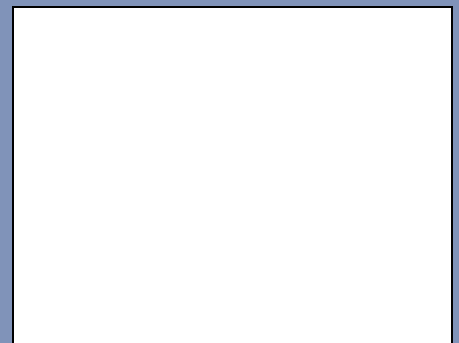

DAIKIN EUROPE N.V.

Naamloze Vennootschap
Zandvoordestraat 300
B-8400 Oostende, Belgium
www.daikin.eu
BTW: BE 0412 120 336
RPR Oostende



EEDEN08-201 • 01/2008 • Copyright © Daikin
The present publication supersedes EEDEN07-200
Prepared in Belgium by Lannoo (www.lannooprint.be), a company whose concern for the environment is set in the EMAS and ISO 14001 systems.
Responsible Editor: Daikin Europe N.V., Zandvoordestraat 300, B- 8400 Oostende